

Titanium[®]

GLENDALE RV

FIFTH WHEELS

Buyers Guide 2004



GLENDALE RECREATIONAL VEHICLES
Building Quality Recreational Vehicles since 1950

Titanium[®]

G L E N D A L E R V

U.S. Patent 6,394,533



Our 33E38TS shown here in our Moss Decor Scheme simply makes you feel right at home on the road.

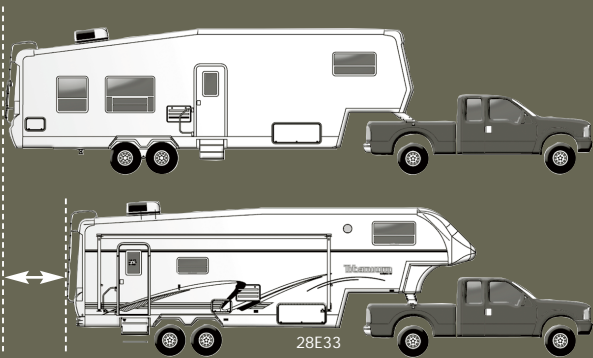

Compare the two fifth wheels of **EQUAL** overall length illustrated above. Titanium's 28E33 shown is considerably shorter in tow versus the competitive traditional fifth wheel design. Comparable interior living space, comfort, and features while enjoying the handling benefit of a much shorter fifth wheel.

ROOF: Quiet, durable, and seamless (EPDM) rubber roof membrane is bonded to plywood. Full 5½" tapered aluminum crown roof structure proves outstanding strength and superior water drainage. Foam core ducted air conditioner with 3½" batt insulation.

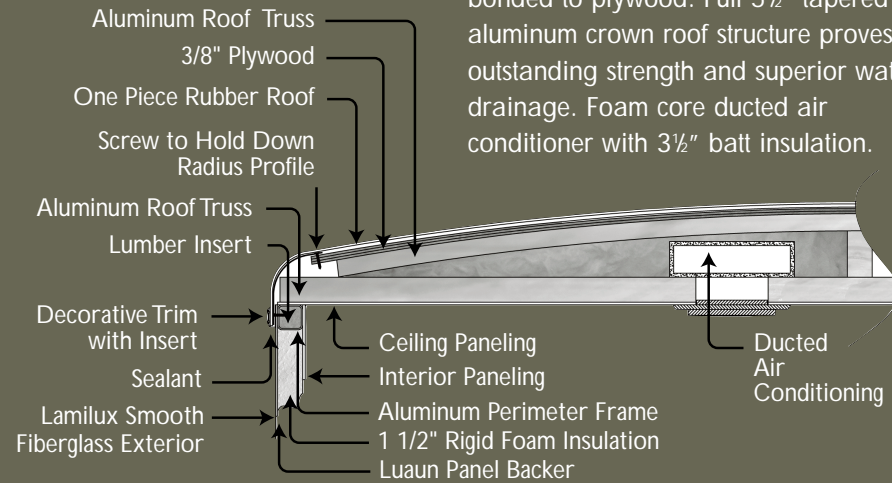

Superior **sidewall** strength and excellent thermal values are achieved by utilizing rigid 1-1/2" thermal foam block insulation. The full lamination vacuum bonding process ensures beam-like structural integrity.

The advantages of our 3-1/2" thick composite **floor** are:

- **lightweight**
- **outstanding strength**
- **superior R-16 thermal insulation**

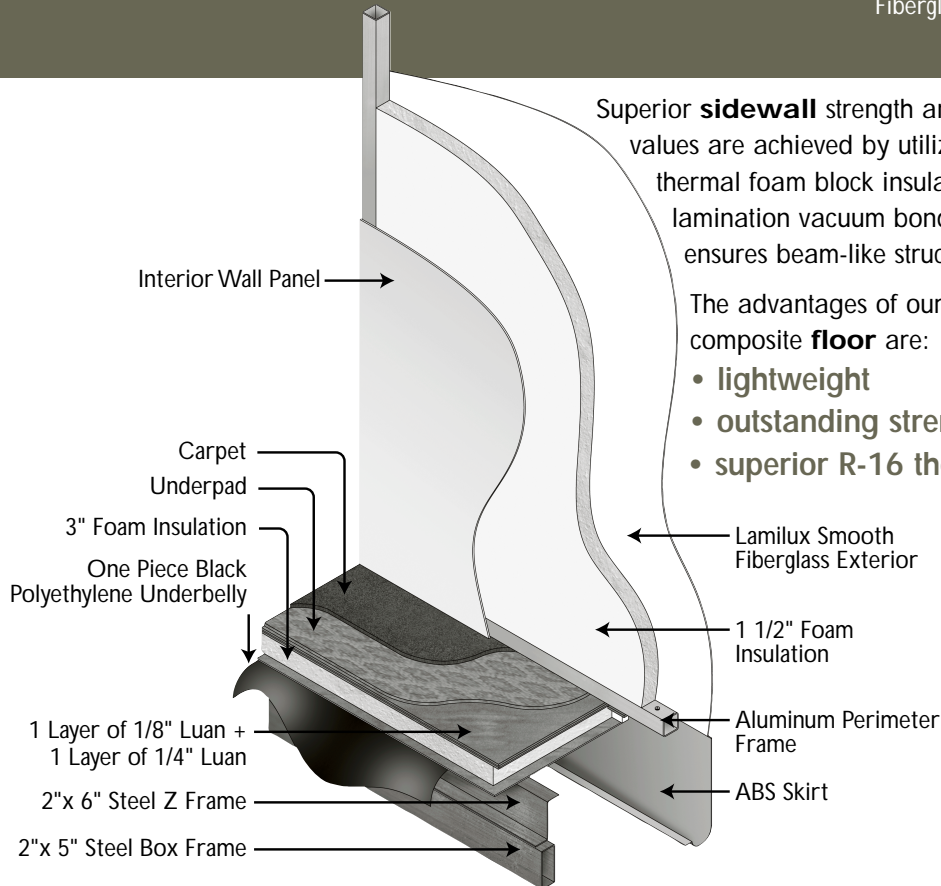

2004 Insulation Values

Ceiling	R-12
Sidewall	R-9
Floor	R-16

ADVANCED ALUMINUM FRAMING

Titanium fifth wheels are constructed using electrically welded 1-1/2" tubular aluminum framing. The aluminum framing is light weight and provides outstanding long term durability.

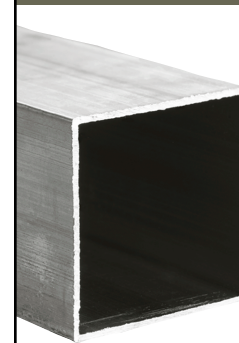

The aluminum framing is used for our engineered roof truss system and for perimeter framing.

2004 Model Year by Glendale RV

STRUCUTURAL

Titanium

GLENDALERV

24E29 Fifth Wheel

by Glendale RV
web site: glendalerv.com

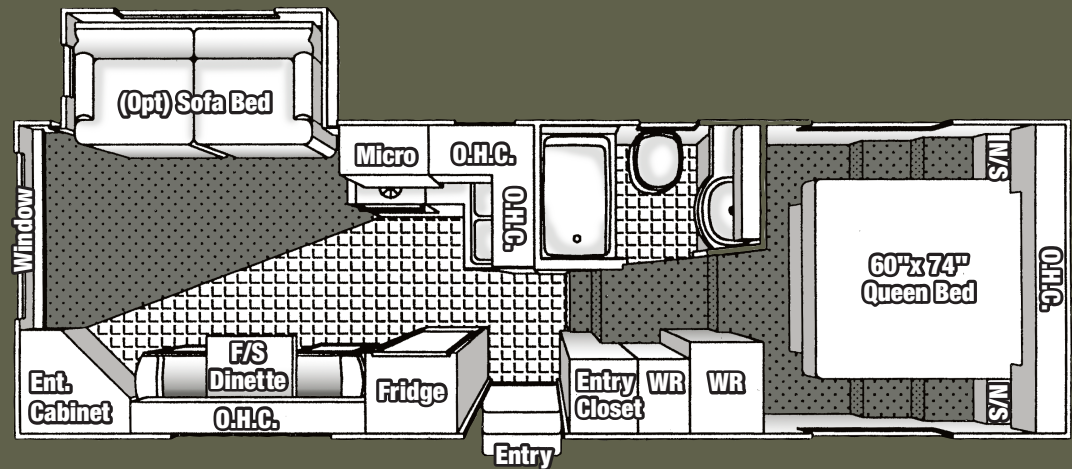

Overall Length	Length - Pin to Bumper	G.V.W.R.	Dry Pin Weight	Dry Weight	Overall Height	Main Body Width
29' - 3"	24' - 1"	8,772 lbs.	1,521 lbs.	6,856 lbs.	12' - 5"	96"

CONSTRUCTION

SIDEWALLS: Vacuum bonded ultra smooth *Lamilux* fiberglass siding. 1-1/2" lightweight aluminum perimeter sidewall framing and 1-1/2" rigid foam insulation.

ROOF: Seamless rubber roof membrane is bonded to 3/8" plywood decking. Full 5-1/2" tapered aluminum truss framing. Thick fiberglass batt insulation. Cathedral ceilings in the bedroom.

FLOOR: Laminated beam floor structure includes 3" foam insulation panel bonded between plywood panels and perimeter framing. *Darco* polythene moisture barrier between chassis underbelly. Seam guard under vinyl floor coverings.

CHASSIS: 11" combination Z channel/steel tube frame construction, twin 5,000 lb. 3" heavy duty axle assemblies, axle shocks at all wheels, *Goodyear* ST225/75R15 "C" radial tires, venting wheel rims, 12" x 2" electric brakes, underslung spare tire and rim, snap release pins on powered front landing gear, powered front landing gear includes a safety shut-off switch, 2 stabilizer jacks, 72 degree adjustable pin box.

SLIDEOUT SPECIFICATIONS: Low maintenance powerful rack and gear 12V direct drive motor system, flush floor design, gear box release lever included for system manual override.

INTERIOR CABINET DOORS: Combination flat and raised panel and cathedral style mirrored oak cabinet doors. Easy-Glide metal roller system on all drawers.

WINDOWS: Radius corner bronze tinted solar reflective glass.

ENTRANCE DOOR: 30" wide radius corner combination entrance door with screen and dead-bolt lock, easy fold-away 24" triple rise entry steps, fold-away assist handle on entry door, porch light.

APPLIANCES

REFRIGERATOR: *Dometic* 8 cubic ft. double door, 2 way gas/110V.

RANGE: *Wedgewood* High Output 21" 3 burner, piezo ignitor.

FURNACE: *Atwood* 2 stage Excalibur furnace 34,000 BTU ducted in floor heat system.

MICROWAVE OVEN: *Dometic* 24" 1.3 cubic ft. with turntable and built in range hood, light and exhaust fan.

AIR CONDITIONER: *Dometic* Briskair 13,500 BTU thermal insulated ducted in ceiling cool air system.

ENTERTAINMENT

STEREO: DVD/Tuner 5 speaker surround sound (*Mandatory Super Pack*).

BEDROOM STEREO: Stereo 12V CD/Clock radio with remote (*Mandatory Super Pack*).

TV ANTENNA: *Winegard* RV antenna with booster.

TV HOOKUP: Coax cable hookup in bedroom and living area.

TELEPHONE JACK: Standard equipment.

SATELLITE HOOKUP: Pre-wired for quick dish connection to the RV.

AWNING

A&E 13' AWNING: Pewter/White. Awning features patented rugged steel roller tube and heavy duty torsion spring with 8' extension.

PLUMBING & ELECTRICAL

Sealand Traveler Lite foot pedal flush china toilet with hand spray (*mandatory option*), *Lyons* tub and surround, folding shower door, single lever brushed nickel faucet in kitchen with sprayer, large brushed nickel double sink (*includes cover*), brushed nickel single lever tap in bathroom, water heater by-pass kit.

WATER PUMP: *Shur-Flo* Smart Sensor Intelligent Pump (*mandatory option*).

WATER HEATER: *Atwood* fast recovery 10 gallon gas/electric (*Direct Spark Ignition*).

HOLDING TANKS: Holding tanks are enclosed, insulated and heated. Garden style non-freeze drain tap on fresh water tank, sewage tank flush system.

HOLDING TANK CAPACITIES:

FRESH: 48 gallon GREY: 49 gallon SEWAGE: 49 gallon

ELECTRICAL CONVERTER: *Progressive Dynamics* 9145A series converter with Charge Wizard.

HOOKUP: 30 AMP.

STANDARD FEATURES

Oak free standing dinette with 2 chairs, fiberglass front and back end caps, roof rack and ladder, oak edge counter tops, daveno, exterior rinse shower, venetian blinds, 2 x 30 lb. propane bottles with auto changeover regulator, systems monitor panel, color coordinated ABS lower sidewall skirting, huge under bed storage cavity, 60" x 74" queen bed, DVD/Tuner 5 speaker surround sound, smoke detector, decorative clock over entry way.

OPTIONAL EQUIPMENT

Twin beds, sofa bed, straight dinette chairs, folding dinette chairs, straight table with 2 chairs, day/night shades, thermopane windows, storm windows, aluminum rims, exterior security lights, blanket box style sofa table, extended pin box assembly, skylight in bathroom, 27" stereo TV, 6,000 lb. axle upgrade.

OPTIONAL FEATURE PACKAGE UPGRADES

INTERIOR PACKAGE: Fluorescent ceiling lights, day/night shades, oak galley area flooring.

COMFORT PACKAGE: 15,000 BTU air conditioner upgrade, *Fantastic* powered roof vent in bedroom, central vacuum.

MANDATORY SUPER PACK FEATURE UPGRADES

Never lube axles, bedroom 12V CD/Clock radio with remote, DVD/Tuner 5 speaker surround sound, bi-fold burner cover, solar panel trickle charger on air conditioner, down draft cool air diverter, brushed nickel single lever kitchen tap set, exterior quick connect for BBQ, new exterior graphics package, mirrored doors in bedroom, cathedral mirrored overhead cabinets in living area, attic vents, oak baseboard and ceiling mouldings, overhead cabinet in bedroom, stainless steel look microwave, bullet style lighting included on overhead cabinets in dinette slideout area, *Progressive Dynamics* 9100 series converter with Charge Wizard.

Titanium

GLENDALERV

26E31DS

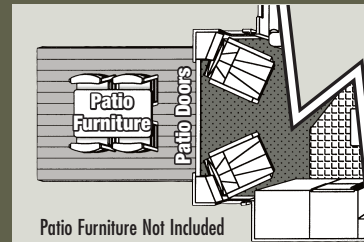
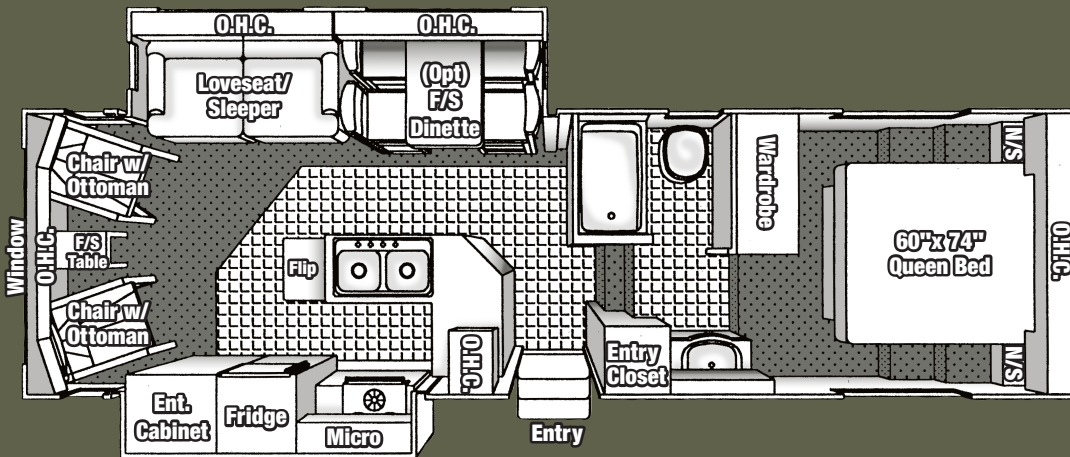

OPTIONAL FLOORPLAN Rear Deck Patio Screen Room

Patent Pending

Overall Length	Length - Pin to Bumper	G.V.W.R.	Dry Pin Weight	Dry Weight	Overall Height	Main Body Width
31' - 11"	26' - 9"	10,614 lbs.	1,709 lbs.	8,392 lbs.	12' - 6"	96"

CONSTRUCTION

SIDEWALLS: Vacuum bonded ultra smooth *Lamilux* fiberglass siding. 1-1/2" lightweight aluminum perimeter sidewall framing and 1-1/2" rigid foam insulation.

ROOF: Seamless rubber roof membrane is bonded to 3/8" plywood decking. Full 5-1/2" tapered aluminum truss framing. Thick fiberglass batt insulation. Cathedral ceilings in the bedroom.

FLOOR: Laminated beam floor structure includes 3" foam insulation panel bonded between plywood panels and perimeter framing. *Darco* polythene moisture barrier between chassis underbelly. Seam guard under vinyl floor coverings.

CHASSIS: 11" combination Z channel/steel tube frame construction, twin 5,000 lb. 3" heavy duty axle assemblies, axle shocks at all wheels, *Goodyear* ST235/80R16 "D" radial tires, venting wheel rims, 12" x 2" electric brakes, underslung spare tire and rim, snap release pins on powered front landing gear, powered front landing gear includes a safety shut-off switch, 2 stabilizer jacks, 72 degree adjustable pin box.

SLIDEOUT SPECIFICATIONS: Low maintenance powerful rack and gear 12V direct drive motor system, flush floor design, gear box release lever included for system manual override.

INTERIOR CABINET DOORS: Combination of raised panel and cathedral style mirrored oak cabinet doors. Easy-Glide metal roller system on all drawers.

WINDOWS: Radius corner bronze tinted solar reflective glass.

ENTRANCE DOOR: 30" wide radius corner combination entrance door with screen and dead-bolt lock, easy fold-away 24" triple rise entry steps, fold-away assist handle on entry door, porch light.

APPLIANCES

REFRIGERATOR: *Dometic* 8 cubic ft. double door, 2 way gas/110V.

RANGE: *Wedgewood* High Output 21" 3 burner, piezo ignitor.

FURNACE: *Atwood* 2 stage Excalibur furnace 34,000 BTU ducted in floor heat system.

MICROWAVE OVEN: *Dometic* 24" 1.3 cubic ft. with turntable and built in range hood, light and exhaust fan.

AIR CONDITIONER: *Dometic* Briskair 13,500 BTU thermal insulated ducted in ceiling cool air system.

ENTERTAINMENT

STEREO: DVD/Tuner 5 speaker surround sound (*Mandatory Super Pack*).

BEDROOM STEREO: Stereo 12V CD/Clock radio with remote (*Mandatory Super Pack*).

TV ANTENNA: *Winegard* RV antenna with booster.

TV HOOKUP: Coax cable hookup in bedroom and living area.

TELEPHONE JACK: Standard equipment.

SATELLITE HOOKUP: Pre-wired for quick dish connection to the RV.

AWNING

A&E 18' AWNING: Pewter/White. Awning features patented rugged steel roller tube and heavy duty torsion spring with 8' extension.

PLUMBING & ELECTRICAL

Sealand Traveler Lite foot pedal flush china toilet with hand spray (*mandatory option*), **Lyons** tub and surround, folding shower door, large brushed nickel double sink in kitchen with single lever faucet and hand sprayer, brushed nickel single lever tap in bathroom, water heater by-pass kit.

WATER PUMP: *Shur-Flo* Smart Sensor Intelligent Pump (*mandatory option*).

WATER HEATER: *Atwood* fast recovery 10 gallon gas/electric (*Direct Spark Ignition*).

HOLDING TANKS: Holding tanks are enclosed, insulated and heated. Garden style non-freeze drain tap on fresh water tank, sewage tank flush system.

HOLDING TANK CAPACITIES:

FRESH: 48 gallon GREY: 49 gallon SEWAGE: 49 gallon

ELECTRICAL CONVERTER: *Progressive Dynamics* 9145A series converter with Charge Wizard.

HOOKUP: 30 AMP.

STANDARD FEATURES

Fiberglass front and back end caps, roof rack and ladder, oak edge counter tops, exterior rinse shower, venetian blinds, 2 x 30 lb. propane bottles with auto changeover regulator, systems monitor panel, color coordinated ABS lower sidewall skirting, huge under bed storage cavity, 60" x 74" queen bed, smoke detector, decorative wall clock, oak valance in kitchen, chairs with ottomans.

OPTIONAL EQUIPMENT

Twin beds, oak free standing dinette in place of booth style dinette, day/night shades, loveseat (*mandatory option*), thermopane windows, storm windows, aluminum rims, exterior security lights, dual powered front landing gear (*mandatory option*), porcelain toilet (*mandatory option*), electric fireplace, skylight above shower with inner dome, 27" stereo TV, 6,000 lb. axle upgrade.

OPTIONAL FEATURE PACKAGE UPGRADES

INTERIOR PACKAGE: Fluorescent ceiling lights, day/night shades, oak galley area flooring.

COMFORT PACKAGE: 15,000 BTU air conditioner upgrade, *Fantastic* powered roof vent in bedroom, central vacuum, paddle fan.

MANDATORY SUPER PACK FEATURE UPGRADES

Never lube axles, bedroom 12V CD/Clock radio with remote, DVD/Tuner 5 speaker surround sound, bi-fold burner cover, solar panel trickle charger on air conditioner, down draft cool air diverter, brushed nickel single lever kitchen tap set, exterior quick connect for BBQ, new exterior graphics package, mirrored doors in bedroom, cathedral mirrored overhead cabinets in living area, attic vents, oak baseboard and ceiling moldings, overhead cabinet in bedroom, stainless steel look microwave, bullet style lighting included on rear overhead cabinets in living area and sofa slideout area, *Progressive Dynamics* 9100 series converter with Charge Wizard.

Titanium

GLENDALERV

28E33 Fifth Wheel

by Glendale RV
web site: glendalerv.com

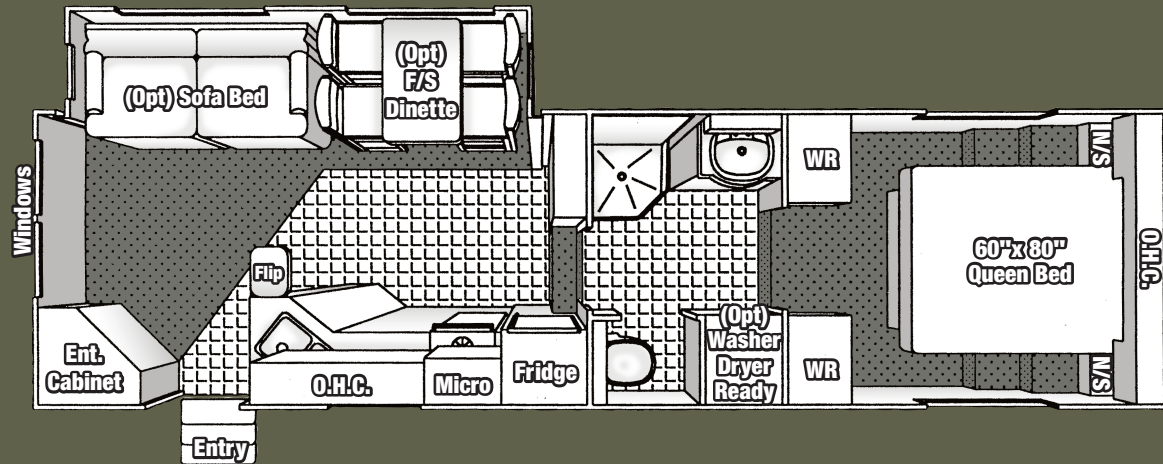

Overall Length	Length - Pin to Bumper	G.V.W.R.	Dry Pin Weight	Dry Weight	Overall Height	Main Body Width
33' - 4"	28' - 2"	10,436 lbs.	1,460 lbs.	8,113 lbs.	12' - 7"	96"

CONSTRUCTION

SIDEWALLS: Vacuum bonded ultra smooth *Lamilux* fiberglass siding. 1-1/2" lightweight aluminum perimeter sidewall framing and 1-1/2" rigid foam insulation.

ROOF: Seamless rubber roof membrane is bonded to 3/8" plywood decking. Full 5-1/2" tapered aluminum truss framing. Thick fiberglass batt insulation. Cathedral ceilings in the bedroom.

FLOOR: Laminated beam floor structure includes 3" foam insulation panel bonded between plywood panels and perimeter framing. *Darco* polythene moisture barrier between chassis underbelly. Seam guard under vinyl floor coverings.

CHASSIS: 11" combination Z channel/steel tube frame construction, twin 5,000 lb. 3" heavy duty axle assemblies, axle shocks at all wheels, *Goodyear* ST235/80R16 "D" radial tires, venting wheel rims, 12" x 2" electric brakes, underslung spare tire and rim, snap release pins on powered front landing gear, powered front landing gear includes a safety shut-off switch, 2 stabilizer jacks, 72 degree adjustable pin box.

SLIDEOUT SPECIFICATIONS: Low maintenance powerful rack and gear 12V direct drive motor system, flush floor design, gear box release lever included for system manual override.

INTERIOR CABINET DOORS: Combination of raised panel and cathedral style mirrored oak cabinet doors. Easy-Glide metal roller system on all drawers.

WINDOWS: Radius corner bronze tinted solar reflective glass.

ENTRANCE DOOR: 30" wide radius corner combination entrance door with screen and dead-bolt lock, easy fold-away 24" triple rise entry steps, fold-away assist handle on entry door, porch light.

APPLIANCES

REFRIGERATOR: *Dometic* 8 cubic ft. double door, 2 way gas/110V.

RANGE: *Wedgewood* High Output 21" 3 burner, piezo ignitor.

FURNACE: *Atwood* 2 stage Excalibur furnace 34,000 BTU ducted in floor heat system.

MICROWAVE OVEN: *Dometic* 24" 1.3 cubic ft. with turntable and built in range hood, light and exhaust fan.

AIR CONDITIONER: *Dometic* Briskair 13,500 BTU thermal insulated ducted in ceiling cool air system.

ENTERTAINMENT

STEREO: DVD/Tuner 5 speaker surround sound (*Mandatory Super Pack*).

BEDROOM STEREO: Stereo 12V CD/Clock radio with remote (*Mandatory Super Pack*).

TV ANTENNA: *Winegard* RV antenna with booster.

TV HOOKUP: Coax cable hookup in bedroom and living area.

TELEPHONE JACK: Standard equipment.

SATELLITE HOOKUP: Pre-wired for quick dish connection to the RV.

AWNING

A&E 19' AWNING: Pewter/White. Awning features patented rugged steel roller tube and heavy duty torsion spring with 8' extension.

PLUMBING & ELECTRICAL

Sealand Traveler Lite foot pedal flush china toilet with hand spray (*mandatory option*), **Lyons** corner shower and surround, single lever brushed nickel faucet in kitchen with sprayer, large brushed nickel double sink (*includes cover*), Euro bath vanity with brushed nickel single lever tap, water heater by-pass kit.

WATER PUMP: *Shur-Flo* Smart Sensor Intelligent Pump (*mandatory option*).

WATER HEATER: *Atwood* fast recovery 10 gallon gas/electric (*Direct Spark Ignition*).

HOLDING TANKS: Holding tanks are enclosed, insulated and heated. Garden style non-freeze drain tap on fresh water tank, sewage tank flush system.

HOLDING TANK CAPACITIES:

FRESH: 48 gallon GREY: 49 gallon SEWAGE: 49 gallon

ELECTRICAL CONVERTER: *Progressive Dynamics* 9145A series converter with Charge Wizard.

HOOKUP: 30 AMP.

STANDARD FEATURES

Fiberglass front and back end caps, roof rack and ladder, oak edge counter tops, davenco, exterior rinse shower, venetian blinds, 2 x 30 lb. propane bottles with auto changeover regulator, systems monitor panel, color coordinated ABS lower sidewall skirting, huge under bed storage cavity, 60" x 80" queen bed, smoke detector, french doors in bedroom.

OPTIONAL EQUIPMENT

Twin beds, sofa bed, oak free standing dinette in place of booth style dinette, day/night shades, thermopane windows, storm windows, aluminum rims, exterior security lights, dual powered front landing gear (*mandatory option*), porcelain toilet (*mandatory option*), electric fireplace, skylight above shower with inner dome, washer/dryer ready, generator ready connection, blanket box style sofa table, 27" stereo TV, 6,000 lb. axle upgrade.

OPTIONAL FEATURE PACKAGE UPGRADES

INTERIOR PACKAGE: Fluorescent ceiling lights, day/night shades, oak galley area flooring.

COMFORT PACKAGE: 15,000 BTU air conditioner upgrade, *Fantastic* powered roof vent in bedroom, central vacuum, paddle fan.

MANDATORY SUPER PACK FEATURE UPGRADES

Never lube axles, bedroom 12V CD/Clock radio with remote, DVD/Tuner 5 speaker surround sound, bi-fold burner cover, solar panel trickle charger on air conditioner, down draft cool air diverter, brushed nickel single lever kitchen tap set, exterior quick connect for BBQ, new exterior graphics package, mirrored doors in bedroom, cathedral mirrored overhead cabinets in living area, attic vents, oak baseboard and ceiling moldings, overhead cabinet in bedroom, stainless steel look microwave, bullet style lighting included on overhead cabinets in dinette/sofa slideout area, *Progressive Dynamics* 9100 series converter with Charge Wizard.

Titanium

GLENDALERV

28E33B Fifth Wheel

by Glendale RV
web site: glendalerv.com

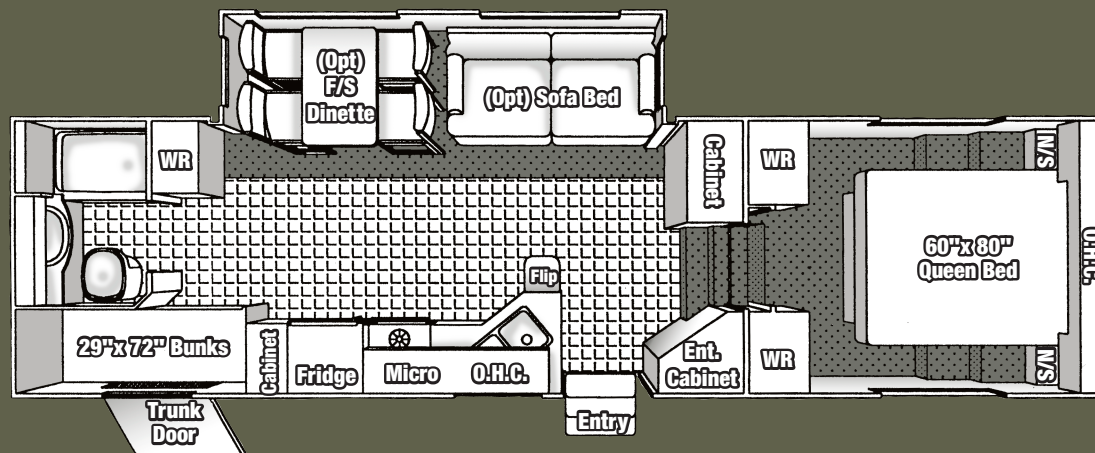

Overall Length	Length - Pin to Bumper	G.V.W.R.	Dry Pin Weight	Dry Weight	Overall Height	Main Body Width
33' - 10"	28' - 8"	10,140 lbs.	1,679 lbs.	7,996 lbs.	12' - 4"	96"

CONSTRUCTION

SIDEWALLS: Vacuum bonded ultra smooth *Lamilux* fiberglass siding and 1-1/2" rigid foam insulation.

ROOF: Seamless rubber roof membrane is bonded to 3/8" plywood decking. Full 5-1/2" tapered aluminum truss framing. Thick fiberglass batt insulation. Cathedral ceilings in the bedroom.

FLOOR: Laminated beam floor structure includes 3" foam insulation panel bonded between plywood panels and perimeter framing. *Darco* polythene moisture barrier between chassis underbelly. Seam guard under vinyl floor coverings.

CHASSIS: 11" combination Z channel/steel tube frame construction, twin 5,000 lb. 3" heavy duty axle assemblies, axle shocks at all wheels, *Goodyear* ST225/75R15 "D" radial tires, venting wheel rims, 12" x 2" electric brakes, underslung spare tire and rim, snap release pins on powered front landing gear, powered front landing gear includes a safety shut-off switch, 2 stabilizer jacks, 72 degree adjustable pin box.

SLIDEOUT SPECIFICATIONS: Low maintenance powerful rack and gear 12V direct drive motor system, flush floor design, gear box release lever included for system manual override.

INTERIOR CABINET DOORS: Combination of raised panel and cathedral style mirrored oak cabinet doors. Easy-Glide metal roller system on all drawers.

WINDOWS: Radius corner bronze tinted solar reflective glass.

ENTRANCE DOOR: 30" wide radius corner combination entrance door with screen and dead-bolt lock, easy fold-away 24" triple rise entry steps, fold-away assist handle on entry door, porch light.

APPLIANCES

REFRIGERATOR: *Dometic* 8 cubic ft. double door, 2 way gas/110V.

RANGE: *Wedgewood* High Output 21" 3 burner, piezo ignitor.

FURNACE: *Atwood* 2 stage Excalibur furnace 34,000 BTU ducted in floor heat system.

MICROWAVE OVEN: *Dometic* 24" 1.3 cubic ft. with turntable and built in range hood, light and exhaust fan.

AIR CONDITIONER: *Dometic* Briskair 13,500 BTU thermal insulated ducted in ceiling cool air system.

ENTERTAINMENT

STEREO: DVD/Tuner 5 speaker surround sound (*Mandatory Super Pack*).

BEDROOM STEREO: Stereo 12V CD/Clock radio with remote (*Mandatory Super Pack*).

TV ANTENNA: *Winegard* RV antenna with booster.

TV HOOKUP: Coax cable hookup in bedroom and living area.

AWNING

A&E 20' AWNING: Pewter/White. Awning features patented rugged steel roller tube and heavy duty torsion spring with 8' extension.

PLUMBING & ELECTRICAL

Sealand Traveler Lite foot pedal flush china toilet with hand spray (*mandatory option*), ABS tub and surround, folding shower door, single lever brushed nickel faucet in kitchen with sprayer, large brushed nickel double sink (*includes cover*), brushed nickel single lever tap in bathroom, water heater by-pass kit.

WATER PUMP: *Shur-Flo* Smart Sensor Intelligent Pump (*mandatory option*).

WATER HEATER: *Atwood* fast recovery 10 gallon gas/electric (*Direct Spark Ignition*).

HOLDING TANKS: Garden style non-freeze drain tap on fresh water tank.

HOLDING TANK CAPACITIES:

FRESH: 48 gallon GREY: 49 gallon SEWAGE: 49 gallon

ELECTRICAL CONVERTER: *Progressive Dynamics* 9145A series converter with Charge Wizard.

HOOKUP: 30 AMP.

STANDARD FEATURES

Fiberglass front and back end caps, roof rack and ladder, oak edge counter tops, davenco, exterior rinse shower, venetian blinds, 2 x 30 lb. propane bottles with auto changeover regulator, systems monitor panel, color coordinated ABS lower sidewall skirting, huge under bed storage cavity, 60" x 80" queen bed, oak valance in kitchen, smoke detector, french doors in bedroom.

OPTIONAL EQUIPMENT

Twin beds, sofa bed, oak free standing dinette in place of booth style dinette, day/night shades, thermopane windows, storm windows, aluminum rims, exterior security lights, axle shock kit, dual powered front landing gear (*mandatory option*), satellite dish hookup, porcelain toilet (*mandatory option*), enclosed insulated holding tanks, skylight in bathroom, 27" stereo TV, 6,000 lb. axle upgrade.

MANDATORY SUPER PACK FEATURE UPGRADES

Never lube axles, bedroom 12V CD/Clock radio with remote, DVD/Tuner 5 speaker surround sound, bi-fold burner cover, solar panel trickle charger on air conditioner, down draft cool air diverter, brushed nickel single lever kitchen tap set, exterior quick connect for BBQ, new exterior graphics package, mirrored doors in bedroom, cathedral mirrored overhead cabinets in living area, attic vents, oak baseboard and ceiling moldings, overhead cabinet in bedroom, stainless steel look microwave, *Progressive Dynamics* 9100 series converter with Charge Wizard.

**"Test tow this
exciting Fifth Wheel
design today!"**

Titanium

GLENDALERV

28E33SB Fifth Wheel

by Glendale RV
web site: glendalerv.com

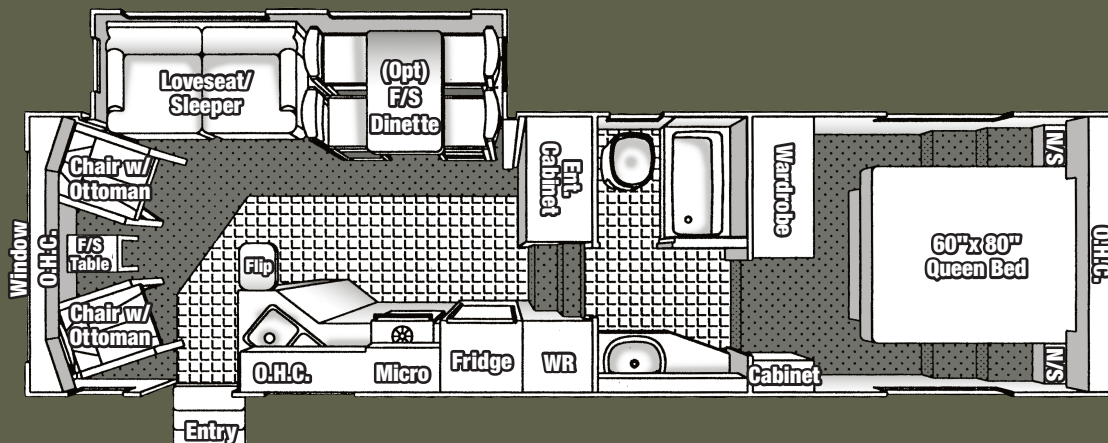

Overall Length	Length - Pin to Bumper	G.V.W.R.	Dry Pin Weight	Dry Weight	Overall Height	Main Body Width
33' - 3"	28' - 1"	10,350 lbs.	1,489 lbs.	8,171 lbs.	12' - 7"	96"

CONSTRUCTION

SIDEWALLS: Vacuum bonded ultra smooth *Lamilux* fiberglass siding. 1-1/2" lightweight aluminum perimeter sidewall framing and 1-1/2" rigid foam insulation.

ROOF: Seamless rubber roof membrane is bonded to 3/8" plywood decking. Full 5-1/2" tapered aluminum truss framing. Thick fiberglass batt insulation. Cathedral ceilings in the bedroom.

FLOOR: Laminated beam floor structure includes 3" foam insulation panel bonded between plywood panels and perimeter framing. *Darco* polythene moisture barrier between chassis underbelly. Seam guard under vinyl floor coverings.

CHASSIS: 11" combination Z channel/steel tube frame construction, twin 5,000 lb. 3" heavy duty axle assemblies, axle shocks at all wheels, *Goodyear* ST235/80R16 "D" radial tires, venting wheel rims, 12" x 2" electric brakes, underslung spare tire and rim, snap release pins on powered front landing gear, powered front landing gear includes a safety shut-off switch, 2 stabilizer jacks, 72 degree adjustable pin box.

SLIDEOUT SPECIFICATIONS: Low maintenance powerful rack and gear 12V direct drive motor system, flush floor design, gear box release lever included for system manual override.

INTERIOR CABINET DOORS: Combination of raised panel and cathedral style mirrored oak cabinet doors. Easy-Glide metal roller system on all drawers.

WINDOWS: Radius corner bronze tinted solar reflective glass.

ENTRANCE DOOR: 30" wide radius corner combination entrance door with screen and dead-bolt lock, easy fold-away 24" triple rise entry steps, fold-away assist handle on entry door, porch light.

APPLIANCES

REFRIGERATOR: *Dometic* 8 cubic ft. double door, 2 way gas/110V.

RANGE: *Wedgewood* High Output 21" 3 burner, piezo ignitor.

FURNACE: *Atwood* 2 stage Excalibur furnace 34,000 BTU ducted in floor heat system.

MICROWAVE OVEN: *Dometic* 24" 1.3 cubic ft. with turntable and built in range hood, light and exhaust fan.

AIR CONDITIONER: *Dometic* Briskair 13,500 BTU thermal insulated ducted in ceiling cool air system.

ENTERTAINMENT

STEREO: DVD/Tuner 5 speaker surround sound (*Mandatory Super Pack*).

BEDROOM STEREO: Stereo 12V CD/Clock radio with remote (*Mandatory Super Pack*).

TV ANTENNA: *Winegard* RV antenna with booster.

TV HOOKUP: Coax cable hookup in bedroom and living area.

TELEPHONE JACK: Standard equipment.

SATELLITE HOOKUP: Pre-wired for quick dish connection to the RV.

AWNING

A&E 19' AWNING: Pewter/White. Awning features patented rugged steel roller tube and heavy duty torsion spring with 8' extension.

PLUMBING & ELECTRICAL

Sealand Traveler Lite foot pedal flush china toilet with hand spray (*mandatory option*), **Lyons** corner shower and surround, single lever brushed nickel faucet in kitchen with sprayer, large brushed nickel double sink (*includes cover*), brushed nickel single lever tap in bathroom, water heater by-pass kit.

WATER PUMP: *Shur-Flo* Smart Sensor Intelligent Pump (*mandatory option*).

WATER HEATER: *Atwood* fast recovery 10 gallon gas/electric (*Direct Spark Ignition*).

HOLDING TANKS: Holding tanks are enclosed, insulated and heated. Garden style non-freeze drain tap on fresh water tank, sewage tank flush system.

HOLDING TANK CAPACITIES:

FRESH: 48 gallon GREY: 49 gallon SEWAGE: 49 gallon

ELECTRICAL CONVERTER: *Progressive Dynamics* 9145A series converter with Charge Wizard.

HOOKUP: 30 AMP.

STANDARD FEATURES

Fiberglass front and back end caps, roof rack and ladder, oak edge counter tops, exterior rinse shower, venetian blinds, 2 x 30 lb. propane bottles with auto changeover regulator, systems monitor panel, color coordinated ABS lower sidewall skirting, huge under bed storage cavity, 60" x 80" queen bed, smoke detector, french doors in bedroom.

OPTIONAL EQUIPMENT

Twin beds, oak free standing dinette in place of booth style dinette, day/night shades, thermopane windows, storm windows, aluminum rims, exterior security lights, dual powered front landing gear (*mandatory option*), porcelain toilet (*mandatory option*), electric fireplace, skylight above shower with inner dome, generator ready connection, blanket box style sofa table, loveseat (*mandatory option*), 27" stereo TV, 6,000 lb. axle upgrade.

OPTIONAL FEATURE PACKAGE UPGRADES

INTERIOR PACKAGE: Fluorescent ceiling lights, day/night shades, oak galley area flooring.

COMFORT PACKAGE: 15,000 BTU air conditioner upgrade, *Fantastic* powered roof vent in bedroom, central vacuum, paddle fan.

MANDATORY SUPER PACK FEATURE UPGRADES

Never lube axles, bedroom 12V CD/Clock radio with remote, DVD/Tuner 5 speaker surround sound, bi-fold burner cover, solar panel trickle charger on air conditioner, down draft cool air diverter, brushed nickel single lever kitchen tap set, exterior quick connect for BBQ, new exterior graphics package, mirrored doors in bedroom, cathedral mirrored overhead cabinets in living area, attic vents, oak baseboard and ceiling moldings, overhead cabinet in bedroom, stainless steel look microwave, bullet style lighting included on overhead cabinets in dinette/sofa slideout area, *Progressive Dynamics* 9100 series converter with Charge Wizard.

Titanium

GLENDALERV

29E34 Fifth Wheel

by Glendale RV
web site: glendalerv.com

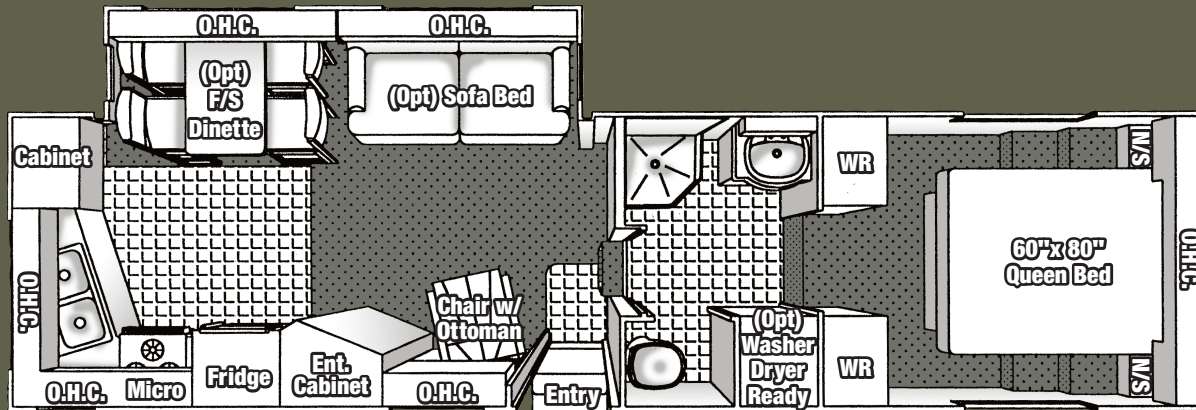

Overall Length	Length - Pin to Bumper	G.V.W.R.	Dry Pin Weight	Dry Weight	Overall Height	Main Body Width
35' - 1"	29' - 11"	10,725 lbs.	1,478 lbs.	8,422 lbs.	12' - 8"	96"

CONSTRUCTION

SIDEWALLS: Vacuum bonded ultra smooth *Lamilux* fiberglass siding. 1-1/2" lightweight aluminum perimeter sidewall framing and 1-1/2" rigid foam insulation.

ROOF: Seamless rubber roof membrane is bonded to 3/8" plywood decking. Full 5-1/2" tapered aluminum truss framing. Thick fiberglass batt insulation. Cathedral ceilings in the bedroom.

FLOOR: Laminated beam floor structure includes 3" foam insulation panel bonded between plywood panels and perimeter framing. *Darco* polythene moisture barrier between chassis underbelly. Seam guard under vinyl floor coverings.

CHASSIS: 11" combination Z channel/steel tube frame construction, twin 5,000 lb. 3" heavy duty axle assemblies, axle shocks at all wheels, *Goodyear* ST235/80R16 "D" radial tires, venting wheel rims, 12" x 2" electric brakes, underslung spare tire and rim, snap release pins on powered front landing gear, powered front landing gear includes a safety shut-off switch, 2 stabilizer jacks, 72 degree adjustable pin box.

SLIDEOUT SPECIFICATIONS: Low maintenance powerful rack and gear 12V direct drive motor system, flush floor design, gear box release lever included for system manual override.

INTERIOR CABINET DOORS: Combination of raised panel and cathedral style mirrored oak cabinet doors. Easy-Glide metal roller system on all drawers.

WINDOWS: Radius corner bronze tinted solar reflective glass.

ENTRANCE DOOR: 30" wide radius corner combination entrance door with screen and dead-bolt lock, easy fold-away 24" triple rise entry steps, fold-away assist handle on entry door, porch light.

APPLIANCES

REFRIGERATOR: *Dometic* 8 cubic ft. double door, 2 way gas/110V.

RANGE: *Wedgewood* High Output 21" 3 burner, piezo ignitor, includes a bi-fold burner cover.

FURNACE: *Atwood* 2 stage Excalibur furnace 34,000 BTU ducted in floor heat system.

MICROWAVE OVEN: *Dometic* 24" 1.3 cubic ft. with turntable and built in range hood, light and exhaust fan.

AIR CONDITIONER: *Dometic* Briskair 13,500 BTU thermal insulated ducted in ceiling cool air system.

ENTERTAINMENT

STEREO: DVD/Tuner 5 speaker surround sound (*Mandatory Super Pack*).

BEDROOM STEREO: Stereo 12V CD/Clock radio with remote (*Mandatory Super Pack*).

TV ANTENNA: *Winegard* RV antenna with booster.

TV HOOKUP: Coax cable hookup in bedroom and living area.

TELEPHONE JACK: Standard equipment.

SATELLITE HOOKUP: Pre-wired for quick dish connection to the RV.

AWNING

A&E 19' AWNING: Pewter/White. Awning features patented rugged steel roller tube and heavy duty torsion spring with 8' extension.

PLUMBING & ELECTRICAL

Sealand Traveler Lite foot pedal flush china toilet with hand spray (*mandatory option*), **Lyons** corner shower and surround, single lever brushed nickel faucet in kitchen with sprayer, large brushed nickel double sink (*includes cover*), Euro bath vanity with brushed nickel single lever tap, water heater by-pass kit.

WATER PUMP: *Shur-Flo* Smart Sensor Intelligent Pump (*mandatory option*).

WATER HEATER: *Atwood* fast recovery 10 gallon gas/electric (*Direct Spark Ignition*).

HOLDING TANKS: Holding tanks are enclosed, insulated and heated. Garden style non-freeze drain tap on fresh water tank, sewage tank flush system.

HOLDING TANK CAPACITIES:

FRESH: 48 gallon GREY: 49 gallon SEWAGE: 49 gallon

ELECTRICAL CONVERTER: *Progressive Dynamics* 9100 series converter with Charge Wizard.

HOOKUP: 30 AMP.

STANDARD FEATURES

Fiberglass front and back end caps, roof rack and ladder, oak edge counter tops, davenco, exterior rinse shower, venetian blinds, 2 x 30 lb. propane bottles with auto changeover regulator, systems monitor panel, color coordinated ABS lower sidewall skirting, huge under bed storage cavity, 60" x 80" queen bed, smoke detector, french doors in bedroom.

OPTIONAL EQUIPMENT

Twin beds, oak free standing dinette in place of booth style dinette, wall-a-way recliner, sofa bed, day/night shades, thermopane windows, storm windows, aluminum rims, exterior security lights, dual powered front landing gear (*mandatory option*), porcelain toilet (*mandatory option*), electric fireplace, washer/dryer ready, generator ready connection, skylight in bathroom, 27" stereo TV, 6,000 lb. axle upgrade.

OPTIONAL FEATURE PACKAGE UPGRADES

INTERIOR PACKAGE: Fluorescent ceiling lights, day/night shades, oak galley area flooring.

COMFORT PACKAGE: 15,000 BTU air conditioner upgrade, *Fantastic* powered roof vent in bedroom, central vacuum, paddle fan.

MANDATORY SUPER PACK FEATURE UPGRADES

Never lube axles, bedroom 12V CD/Clock radio with remote, DVD/Tuner 5 speaker surround sound, bi-fold burner cover, solar panel trickle charger on air conditioner, down draft cool air diverter, brushed nickel single lever kitchen tap set, exterior quick connect for BBQ, new exterior graphics package, mirrored doors in bedroom, cathedral mirrored overhead cabinets in living area, attic vents, oak baseboard and ceiling moldings, overhead cabinet in bedroom, stainless steel look microwave, bullet style lighting included on overhead cabinets in dinette/sofa slideout area, *Progressive Dynamics* 9100 series converter with Charge Wizard.

Titanium

GLENDALERV

29E34MS

Fifth Wheel

by Glendale RV
web site: glendalerv.com

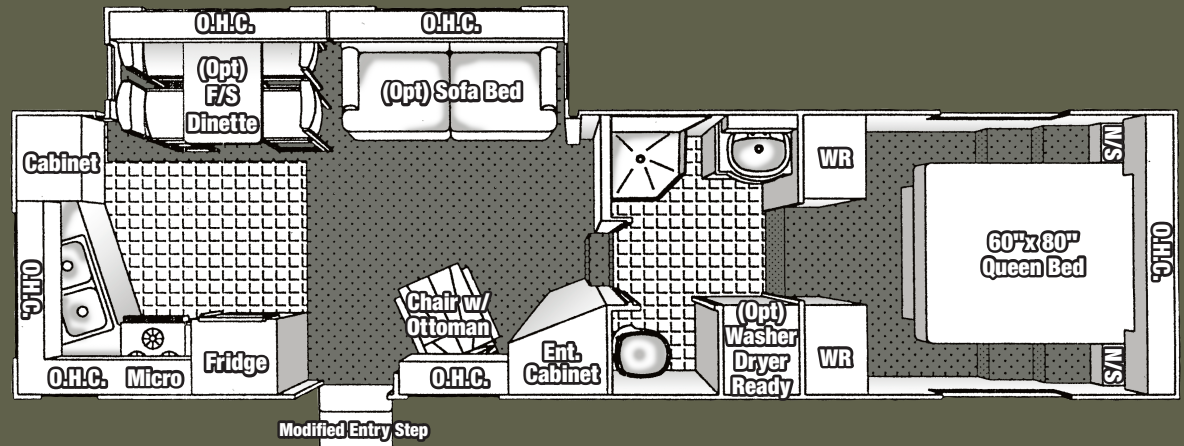

Overall Length	Length - Pin to Bumper	G.V.W.R.	Dry Pin Weight	Dry Weight	Overall Height	Main Body Width
35' - 1"	29' - 11"	10,571 lbs.	1,443 lbs.	8,351 lbs.	12' - 8"	96"

CONSTRUCTION

SIDEWALLS: Vacuum bonded ultra smooth *Lamilux* fiberglass siding. 1-1/2" lightweight aluminum perimeter sidewall framing and 1-1/2" rigid foam insulation.

ROOF: Seamless rubber roof membrane is bonded to 3/8" plywood decking. Full 5-1/2" tapered aluminum truss framing. Thick fiberglass batt insulation. Cathedral ceilings in the bedroom.

FLOOR: Laminated beam floor structure includes 3" foam insulation panel bonded between plywood panels and perimeter framing. *Darco* polythene moisture barrier between chassis underbelly. Seam guard under vinyl floor coverings.

CHASSIS: 11" combination Z channel/steel tube frame construction, twin 5,000 lb. 3" heavy duty axle assemblies, axle shocks at all wheels, *Goodyear* ST235/80R16 "D" radial tires, venting wheel rims, 12" x 2" electric brakes, underslung spare tire and rim, snap release pins on powered front landing gear, powered front landing gear includes a safety shut-off switch, 2 stabilizer jacks, 72 degree adjustable pin box.

SLIDEOUT SPECIFICATIONS: Low maintenance powerful rack and gear 12V direct drive motor system, flush floor design, gear box release lever included for system manual override.

INTERIOR CABINET DOORS: Combination of raised panel and cathedral style mirrored oak cabinet doors. Easy-Glide metal roller system on all drawers.

WINDOWS: Radius corner bronze tinted solar reflective glass.

ENTRANCE DOOR: 30" wide radius corner combination entrance door with screen and dead-bolt lock, easy fold-away 24" triple rise entry steps, fold-away assist handle on entry door, porch light.

APPLIANCES

REFRIGERATOR: *Dometic* 8 cubic ft. double door, 2 way gas/110V.

RANGE: *Wedgewood* High Output 21" 3 burner, piezo ignitor, includes a bi-fold burner cover.

FURNACE: *Atwood* 2 stage Excalibur furnace 40,000 BTU ducted in floor heat system.

MICROWAVE OVEN: *Dometic* 24" 1.3 cubic ft. with turntable and built in range hood, light and exhaust fan.

AIR CONDITIONER: *Dometic* Briskair 13,500 BTU thermal insulated ducted in ceiling cool air system.

ENTERTAINMENT

STEREO: DVD/Tuner 5 speaker surround sound (*Mandatory Super Pack*).

BEDROOM STEREO: Stereo 12V CD/Clock radio with remote (*Mandatory Super Pack*).

TV ANTENNA: *Winegard* RV antenna with booster.

TV HOOKUP: Coax cable hookup in bedroom and living area.

TELEPHONE JACK: Standard equipment.

SATELLITE HOOKUP: Pre-wired for quick dish connection to the RV.

AWNING

A&E 19' AWNING: Pewter/White. Awning features patented rugged steel roller tube and heavy duty torsion spring with 8' extension.

PLUMBING & ELECTRICAL

Sealand Traveler Lite foot pedal flush china toilet with hand spray (*mandatory option*), **Lyons** corner shower and surround, single lever brushed nickel faucet in kitchen with sprayer, large brushed nickel double sink (*includes cover*), Euro bath vanity with brushed nickel single lever tap, water heater by-pass kit.

WATER PUMP: *Shur-Flo* Smart Sensor Intelligent Pump (*mandatory option*).

WATER HEATER: *Atwood* fast recovery 10 gallon gas/electric (*Direct Spark Ignition*).

HOLDING TANKS: Holding tanks are enclosed, insulated and heated. Garden style non-freeze drain tap on fresh water tank, sewage tank flush system.

HOLDING TANK CAPACITIES:

FRESH: 48 gallon GREY: 49 gallon SEWAGE: 49 gallon

ELECTRICAL CONVERTER: *Progressive Dynamics* 9100 series converter with Charge Wizard.

HOOKUP: 30 AMP.

STANDARD FEATURES

Fiberglass front and back end caps, roof rack and ladder, oak edge counter tops, daveno, exterior rinse shower, venetian blinds, 2 x 30 lb. propane bottles with auto changeover regulator, systems monitor panel, color coordinated ABS lower sidewall skirting, huge under bed storage cavity, 60" x 80" queen bed, smoke detector, french doors in bedroom, chair with ottoman, unique fold-away mid step.

OPTIONAL EQUIPMENT

Twin beds, oak free standing dinette in place of booth style dinette, wall-a-way recliner, sofa bed, day/night shades, thermopane windows, storm windows, aluminum rims, exterior security lights, dual powered front landing gear (*mandatory option*), porcelain toilet (*mandatory option*), electric fireplace, washer/dryer ready, generator ready connection, skylight in bathroom, 6,000 lb. axle upgrade.

OPTIONAL FEATURE PACKAGE UPGRADES

INTERIOR PACKAGE: Fluorescent ceiling lights, day/night shades, oak galley area flooring.

COMFORT PACKAGE: 15,000 BTU air conditioner upgrade, *Fantastic* powered roof vent in bedroom, central vacuum, paddle fan.

MANDATORY SUPER PACK FEATURE UPGRADES

Never lube axles, bedroom 12V CD/Clock radio with remote, DVD/Tuner 5 speaker surround sound, bi-fold burner cover, solar panel trickle charger on air conditioner, down draft cool air diverter, brushed nickel single lever kitchen tap set, exterior quick connect for BBQ, new exterior graphics package, mirrored doors in bedroom, cathedral mirrored overhead cabinets in living area, attic vents, oak baseboard and ceiling moldings, overhead cabinet in bedroom, stainless steel look microwave, bullet style lighting included on overhead cabinets in dinette/sofa slideout area, *Progressive Dynamics* 9100 series converter with Charge Wizard.

Titanium[®]

G L E N D A L E R V



Model 26E31DS in the Antique Rose Decor Scheme



32E37DS shown here in our Antique Rose Decor



Relax in comfort and style with our optional wall-a-way recliners



Titanium offers an abundant amount of overhead cabinet storage throughout all model layouts

Once again, Glendale has
achieved another industry first.

NEW for 2004...





The Bug Room

Patent Pending

Glendale's Exceptional New Option for selected models.

Come and Check out this Design today!!!!

Titanium[®]



This screened in deck area concept will simply allow for those leisurely activities to be enjoyed in a COMFORTABLE Outdoor atmosphere.

We got the Bugs Out!

This Optional floor plan layout is offered on our models 26E31DS, 29E34RL, 32E37DS, and 33E38TS.



Titanium[®]

GLENDALE RV



Titanium offers comfort with our optional Free Standing Dinette and Sofa Bed which also converts into an actual Queen size bed.



29E34RL Kitchen design has been a popular choice with it's versatile counter and cabinet storage



Convenient overhead cabinets and NEW European style look in all Titanium bedroom layouts



Model 30E35RB in the Ocean Blue Decor Scheme

Titanium

GLENDALERV

29E34RL

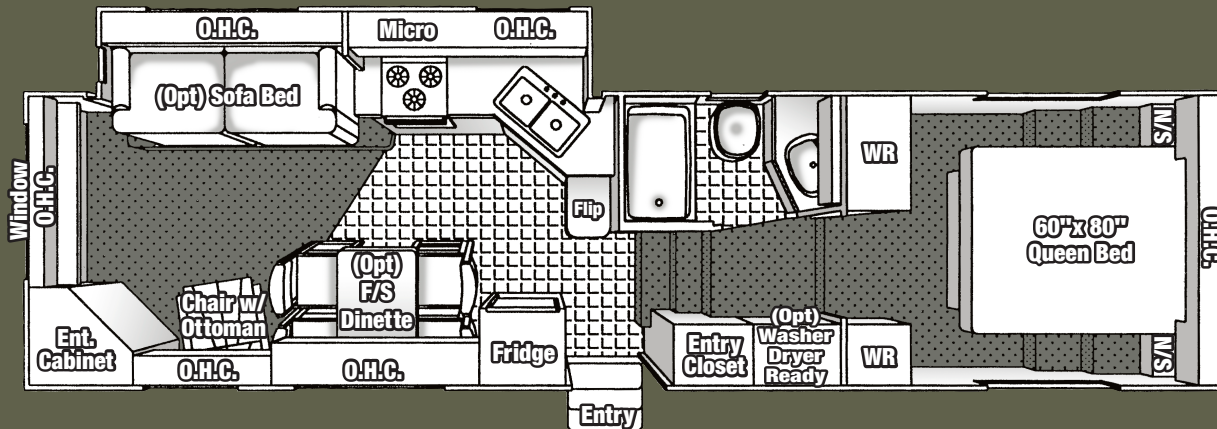

Overall Length	Length - Pin to Bumper	G.V.W.R.	Dry Pin Weight	Dry Weight	Overall Height	Main Body Width
34' - 11"	29' - 9"	10,802 lbs.	1,727 lbs.	8,545 lbs.	12' - 8"	96"

CONSTRUCTION

SIDEWALLS: Vacuum bonded ultra smooth *Lamilux* fiberglass siding. 1-1/2" lightweight aluminum perimeter sidewall framing and 1-1/2" rigid foam insulation.

ROOF: Seamless rubber roof membrane is bonded to 3/8" plywood decking. Full 5-1/2" tapered aluminum truss framing. Thick fiberglass batt insulation. Cathedral ceilings in the bedroom.

FLOOR: Laminated beam floor structure includes 3" foam insulation panel bonded between plywood panels and perimeter framing. *Darco* polythene moisture barrier between chassis underbelly. Seam guard under vinyl floor coverings.

CHASSIS: 11" combination Z channel/steel tube frame construction, twin 5,000 lb. 3" heavy duty axle assemblies, axle shocks at all wheels, *Goodyear* ST235/80R16 "D" radial tires, venting wheel rims, 12" x 2" electric brakes, underslung spare tire and rim, snap release pins on powered front landing gear, powered front landing gear includes a safety shut-off switch, 2 stabilizer jacks, 72 degree adjustable pin box.

SLIDEOUT SPECIFICATIONS: Low maintenance powerful rack and gear 12V direct drive motor system, flush floor design, gear box release lever included for system manual override.

INTERIOR CABINET DOORS: Combination of raised panel and cathedral style mirrored oak cabinet doors. Easy-Glide metal roller system on all drawers.

WINDOWS: Radius corner bronze tinted solar reflective glass.

ENTRANCE DOOR: 30" wide radius corner combination entrance door with screen and dead-bolt lock, easy fold-away 24" triple rise entry steps, fold-away assist handle on entry door, porch light.

APPLIANCES

REFRIGERATOR: *Dometic* 8 cubic ft. double door, 2 way gas/110V.

RANGE: *Wedgewood* High Output 21" 3 burner, piezo ignitor, includes a bi-fold burner cover.

FURNACE: *Atwood* 2 stage Excalibur furnace 34,000 BTU ducted in floor heat system.

MICROWAVE OVEN: *Dometic* 24" 1.3 cubic ft. with turntable and built in range hood, light and exhaust fan.

AIR CONDITIONER: *Dometic* Briskair 13,500 BTU thermal insulated ducted in ceiling cool air system.

ENTERTAINMENT

STEREO: DVD/Tuner 5 speaker surround sound (*Mandatory Super Pack*).

BEDROOM STEREO: Stereo 12V CD/Clock radio with remote (*Mandatory Super Pack*).

TV ANTENNA: *Winegard* RV antenna with booster.

TV HOOKUP: Coax cable hookup in bedroom and living area.

TELEPHONE JACK: Standard equipment.

SATELLITE HOOKUP: Pre-wired for quick dish connection to the RV.

AWNING

A&E 19' AWNING: Pewter/White. Awning features patented rugged steel roller tube and heavy duty torsion spring with 8' extension.

PLUMBING & ELECTRICAL

Sealand Traveler Lite foot pedal flush china toilet with hand spray (*mandatory option*), **Lyons** tub and surround, single lever brushed nickel faucet in kitchen with sprayer, large brushed nickel under sink (*includes cover*), brushed nickel single lever tap in bathroom, water heater by-pass kit.

WATER PUMP: *Shur-Flo* Smart Sensor Intelligent Pump (*mandatory option*).

WATER HEATER: *Atwood* fast recovery 10 gallon gas/electric (*Direct Spark Ignition*).

HOLDING TANKS: Holding tanks are enclosed, insulated and heated. Garden style non-freeze drain tap on fresh water tank, sewage tank flush system.

HOLDING TANK CAPACITIES:

FRESH: 48 gallon GREY: 49 gallon SEWAGE: 49 gallon

ELECTRICAL CONVERTER: *Progressive Dynamics* 9145A series converter with Charge Wizard.

HOOKUP: 30 AMP.

STANDARD FEATURES

Fiberglass front and back end caps, roof rack and ladder, oak edge counter tops, davenco, exterior rinse shower, venetian blinds, 2 x 30 lb. propane bottles with auto changeover regulator, systems monitor panel, color coordinated ABS lower sidewall skirting, huge under bed storage cavity, 60" x 80" queen bed, smoke detector, french doors in bedroom, chair with ottoman.

OPTIONAL EQUIPMENT

Twin beds, oak free standing dinette in place of booth style dinette, wall-a-way recliner, sofa bed, day/night shades, thermopane windows, storm windows, aluminum rims, exterior security lights, dual powered front landing gear (*mandatory option*), porcelain toilet (*mandatory option*), electric fireplace, washer/dryer ready, generator ready connection, skylight in bathroom, 27" stereo TV, 6,000 lb. axle upgrade.

OPTIONAL FEATURE PACKAGE UPGRADES

INTERIOR PACKAGE: Fluorescent ceiling lights, day/night shades, oak galley area flooring.

COMFORT PACKAGE: 15,000 BTU air conditioner upgrade, *Fantastic* powered roof vent in bedroom, central vacuum, paddle fan.

MANDATORY SUPER PACK FEATURE UPGRADES

Never lube axles, bedroom 12V CD/Clock radio with remote, DVD/Tuner 5 speaker surround sound, bi-fold burner cover, solar panel trickle charger on air conditioner, down draft cool air diverter, brushed nickel single lever kitchen tap set, exterior quick connect for BBQ, new exterior graphics package, mirrored doors in bedroom, cathedral mirrored overhead cabinets in living area, attic vents, oak baseboard and ceiling moldings, overhead cabinet in bedroom, stainless steel look microwave, bullet style lighting included on overhead cabinets in living area and sofa slideout area, *Progressive Dynamics* 9100 series converter with Charge Wizard.

Titanium

GLENDALER V

30E35DS

Fifth Wheel

by Glendale RV
web site: glendalerv.com

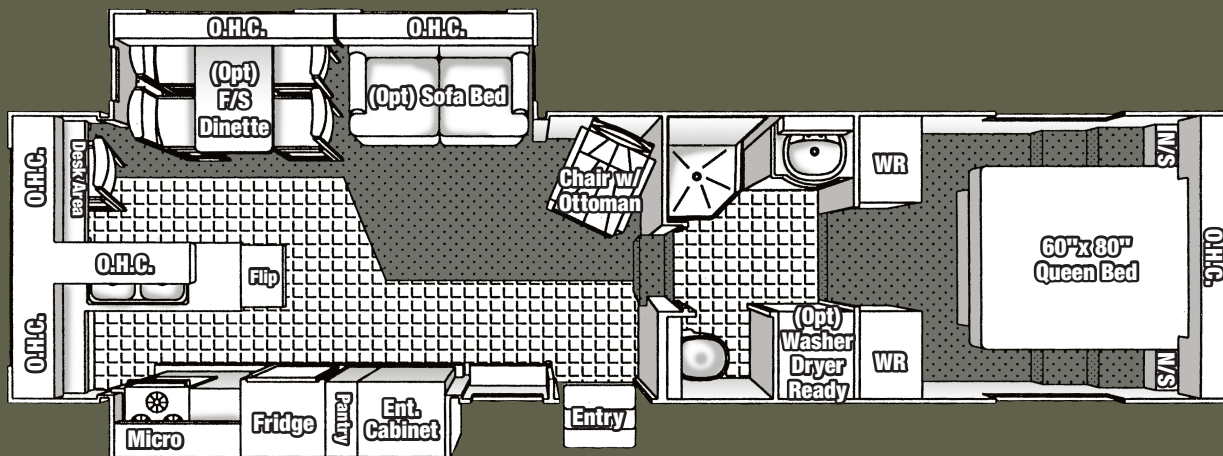

Overall Length	Length - Pin to Bumper	G.V.W.R.	Dry Pin Weight	Dry Weight	Overall Height	Main Body Width
36' - 4"	31' - 2"	11,915 lbs.	1,591 lbs.	9,460 lbs.	12' - 8"	96"

CONSTRUCTION

SIDEWALLS: Vacuum bonded ultra smooth *Lamilux* fiberglass siding. 1-1/2" lightweight aluminum perimeter sidewall framing and 1-1/2" rigid foam insulation.

ROOF: Seamless rubber roof membrane is bonded to 3/8" plywood decking. Full 5-1/2" tapered aluminum truss framing. Thick fiberglass batt insulation. Cathedral ceilings in the bedroom.

FLOOR: Laminated beam floor structure includes 3" foam insulation panel bonded between plywood panels and perimeter framing. *Darco* polyethylene moisture barrier between chassis underbelly. Seam guard under vinyl floor coverings.

CHASSIS: 11" combination Z channel/steel tube frame construction, twin 6,000 lb. 3" heavy duty axle assemblies, axle shocks at all wheels, *Goodyear* ST235/80R16 "D" radial tires, venting wheel rims, 12" x 2" electric brakes, underslung spare tire and rim, snap release pins on powered front landing gear, powered front landing gear includes a safety shut-off switch, 2 stabilizer jacks, 72 degree adjustable pin box.

SLIDEOUT SPECIFICATIONS: Low maintenance powerful rack and gear 12V direct drive motor system, flush floor design, gear box release lever included for system manual override.

INTERIOR CABINET DOORS: Combination of raised panel and cathedral style mirrored oak cabinet doors. Easy-Glide metal roller system on all drawers.

WINDOWS: Radius corner bronze tinted solar reflective glass.

ENTRANCE DOOR: 30" wide radius corner combination entrance door with screen and dead-bolt lock, easy fold-away 24" triple rise entry steps, fold-away assist handle on entry door, porch light.

APPLIANCES

REFRIGERATOR: *Dometic* 8 cubic ft. double door, 2 way gas/110V.

RANGE: *Wedgewood* High Output 21" 3 burner, piezo ignitor, includes a bi-fold burner cover.

FURNACE: *Atwood* 2 stage Excalibur furnace 40,000 BTU ducted in floor heat system.

MICROWAVE OVEN: *Dometic* 24" 1.3 cubic ft. with turntable and built in range hood, light and exhaust fan.

AIR CONDITIONER: *Dometic* Briskair 13,500 BTU thermal insulated ducted in ceiling cool air system.

ENTERTAINMENT

STEREO: DVD/Tuner 5 speaker surround sound (*Mandatory Super Pack*).

BEDROOM STEREO: Stereo 12V CD/Clock radio with remote (*Mandatory Super Pack*).

TV ANTENNA: *Winegard* RV antenna with booster.

TV HOOKUP: Coax cable hookup in bedroom and living area.

TELEPHONE JACK: Standard equipment.

SATELLITE HOOKUP: Pre-wired for quick dish connection to the RV.

AWNING

A&E 22' AWNING: Pewter/White. Awning features patented rugged steel roller tube and heavy duty torsion spring with 8' extension.

PLUMBING & ELECTRICAL

Sealand Traveler Lite foot pedal flush china toilet with hand spray (*mandatory option*), **Lyons** corner shower and surround, single lever brushed nickel faucet in kitchen with sprayer, large brushed nickel double sink (*includes cover*), Euro bath vanity with brushed nickel single lever tap, water heater by-pass kit.

WATER PUMP: *Shur-Flo* Smart Sensor Intelligent Pump (*mandatory option*).

WATER HEATER: *Atwood* fast recovery 10 gallon gas/electric DSI with remote switch operation.

HOLDING TANKS: Holding tanks are enclosed, insulated and heated. Garden style non-freeze drain tap on fresh water tank, sewage tank flush system.

HOLDING TANK CAPACITIES:

FRESH: 48 gallon GREY: 49 gallon SEWAGE: 49 gallon

ELECTRICAL CONVERTER: *Magnetek* 7445 solid state circuitry, whisper quiet operation.

HOOKUP: 50 AMP (*detachable power cord*).

STANDARD FEATURES

Fiberglass front and back end caps, roof rack and ladder, oak edge counter tops, exterior rinse shower, venetian blinds, 2 x 30 lb. propane bottles with auto changeover regulator, systems monitor panel, color coordinated ABS lower sidewall skirting, under bed storage compartment, 60" x 80" queen bed, smoke detector, french doors in bedroom, chair with ottoman.

OPTIONAL EQUIPMENT

Twin beds, oak free standing dinette in place of booth style dinette, wall-a-way recliners, sofa bed, day/night shades, thermopane windows, storm windows, aluminum rims, dual exterior security lights, porcelain toilet (*mandatory option*), electric fireplace, washer/dryer ready, generator ready connection, skylight in bathroom, 27" TV with swivel base, dual front power jacks (*mandatory option*).

OPTIONAL FEATURE PACKAGE UPGRADES

INTERIOR PACKAGE: Fluorescent ceiling lights, day/night shades, oak galley area flooring.

COMFORT PACKAGE: 15,000 BTU air conditioner upgrade, *Fantastic* powered roof vent in bedroom, central vacuum, paddle fan.

MANDATORY SUPER PACK FEATURE UPGRADES

Never lube axles, bedroom 12V CD/Clock radio with remote, DVD/Tuner 5 speaker surround sound, bi-fold burner cover, solar panel trickle charger on air conditioner, down draft cool air diverter, brushed nickel single lever kitchen tap set, exterior quick connect for BBQ, new exterior graphics package, mirrored doors in bedroom, cathedral mirrored overhead cabinets in living area, attic vents, oak baseboard and ceiling moldings, overhead cabinet in bedroom, stainless steel look microwave, bullet style lighting included on overhead cabinets in dinette/sofa slideout area.

Titanium

GLENDALERV

30E35RB

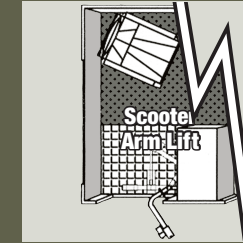
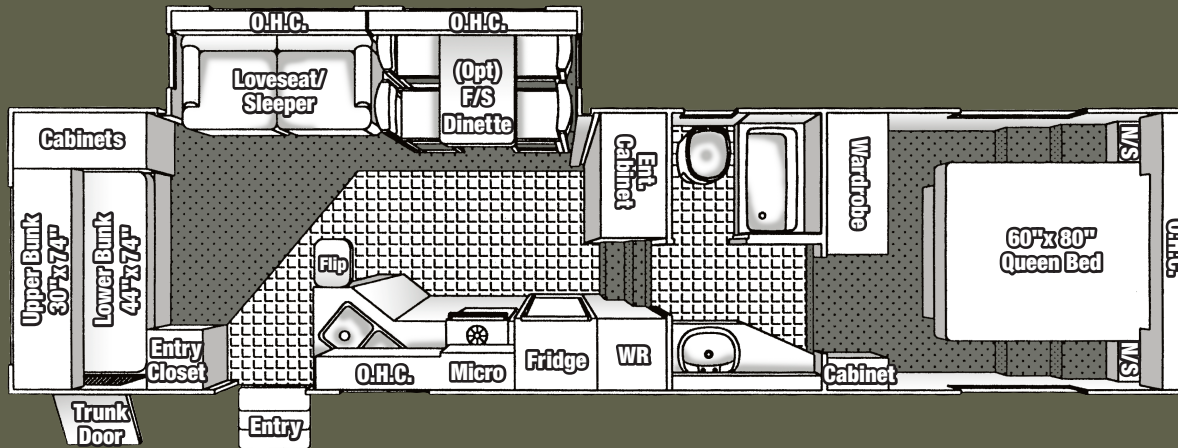

OPTIONAL
FLOORPLAN
LAYOUT
"Scooter Lift"

Overall Length	Length - Pin to Bumper	G.V.W.R.	Dry Pin Weight	Dry Weight	Overall Height	Main Body Width
35' - 10"	30' - 8"	10,994 lbs.	1,657 lbs.	8,708 lbs.	12' - 8"	96"

CONSTRUCTION

SIDEWALLS: Vacuum bonded ultra smooth *Lamilux* fiberglass siding. 1-1/2" lightweight aluminum perimeter sidewall framing and 1-1/2" rigid foam insulation.

ROOF: Seamless rubber roof membrane is bonded to 3/8" plywood decking. Full 5-1/2" tapered aluminum truss framing. Thick fiberglass batt insulation. Cathedral ceilings in the bedroom.

FLOOR: Laminated beam floor structure includes 3" foam insulation panel bonded between plywood panels and perimeter framing. *Darco* polythene moisture barrier between chassis underbelly. Seam guard under vinyl floor coverings.

CHASSIS: 11" combination Z channel/steel tube frame construction, twin 5,000 lb. 3" heavy duty axle assemblies, axle shocks at all wheels, *Goodyear* ST235/80R16 "D" radial tires, venting wheel rims, 12" x 2" electric brakes, underslung spare tire and rim, snap release pins on powered front landing gear, powered front landing gear includes a safety shut-off switch, 2 stabilizer jacks, 72 degree adjustable pin box.

SLIDEOUT SPECIFICATIONS: Low maintenance powerful rack and gear 12V direct drive motor system, flush floor design, gear box release lever included for system manual override.

INTERIOR CABINET DOORS: Combination of raised panel and cathedral style mirrored oak cabinet doors. Easy-Glide metal roller system on all drawers.

WINDOWS: Radius corner bronze tinted solar reflective glass.

ENTRANCE DOOR: 30" wide radius corner combination entrance door with screen and dead-bolt lock, easy fold-away 24" triple rise entry steps, fold-away assist handle on entry door, porch light.

APPLIANCES

REFRIGERATOR: *Dometic* 8 cubic ft. double door, 2 way gas/110V.

RANGE: *Wedgewood* High Output 21" 3 burner, piezo ignitor, includes a bi-fold burner cover.

FURNACE: *Atwood* 2 stage Excalibur furnace 40,000 BTU ducted in floor heat system.

MICROWAVE OVEN: *Dometic* 24" 1.3 cubic ft. with turntable and built in range hood, light and exhaust fan.

AIR CONDITIONER: *Dometic* Briskair 13,500 BTU thermal insulated ducted in ceiling cool air system.

ENTERTAINMENT

STEREO: DVD/Tuner 5 speaker surround sound (*Mandatory Super Pack*).

BEDROOM STEREO: Stereo 12V CD/Clock radio with remote (*Mandatory Super Pack*).

TV ANTENNA: *Winegard* RV antenna with booster.

TV HOOKUP: Coax cable hookup in bedroom and living area.

TELEPHONE JACK: Standard equipment.

SATELLITE HOOKUP: Pre-wired for quick dish connection to the RV.

AWNING

A&E 19' AWNING: Pewter/White. Awning features patented rugged steel roller tube and heavy duty torsion spring with 8' extension.

PLUMBING & ELECTRICAL

Sealand Traveler Lite foot pedal flush china toilet with hand spray (*mandatory option*), **Lyons** tub and surround, single lever brushed nickel faucet in kitchen with sprayer, large brushed nickel double sink (*includes cover*), brushed nickel single lever tap in bathroom, water heater by-pass kit.

WATER PUMP: *Shur-Flo* Smart Sensor Intelligent Pump (*mandatory option*).

WATER HEATER: *Atwood* fast recovery 10 gallon gas/electric (*Direct Spark Ignition*).

HOLDING TANKS: Holding tanks are enclosed, insulated and heated. Garden style non-freeze drain tap on fresh water tank, sewage tank flush system.

HOLDING TANK CAPACITIES:

FRESH: 48 gallon GREY: 49 gallon SEWAGE: 49 gallon

ELECTRICAL CONVERTER: *Progressive Dynamics* 9145A series converter with Charge Wizard.

HOOKUP: 30 AMP.

STANDARD FEATURES

Fiberglass front and back end caps, roof rack and ladder, oak edge counter tops, davenco, exterior rinse shower, venetian blinds, 2 x 30 lb. propane bottles with auto changeover regulator, systems monitor panel, color coordinated ABS lower sidewall skirting, under bed storage compartment, 60" x 80" queen bed, smoke detector, french doors in bedroom, axle shocks kit.

OPTIONAL EQUIPMENT

Twin beds, oak free standing dinette in place of booth style dinette, wall-a-way recliner, day/night shades, thermopane windows, storm windows, aluminum rims, exterior security lights, dual powered front landing gear (*mandatory option*), porcelain toilet (*mandatory option*), electric fireplace, generator ready connection, skylight in bathroom, loveseat (*mandatory option*), 27" stereo TV, 6,000 lb. axle upgrade.

OPTIONAL FEATURE PACKAGE UPGRADES

INTERIOR PACKAGE: Fluorescent ceiling lights, day/night shades, oak galley area flooring.

COMFORT PACKAGE: 15,000 BTU air conditioner upgrade, *Fantastic* powered roof vent in bedroom, central vacuum, paddle fan.

MANDATORY SUPER PACK FEATURE UPGRADES

Never lube axles, bedroom 12V CD/Clock radio with remote, DVD/Tuner 5 speaker surround sound, bi-fold burner cover, solar panel trickle charger on air conditioner, down draft cool air diverter, brushed nickel single lever kitchen tap set, exterior quick connect for BBQ, new exterior graphics package, mirrored doors in bedroom, cathedral mirrored overhead cabinets in living area, attic vents, oak baseboard and ceiling moldings, overhead cabinet in bedroom, stainless steel look microwave, bullet style lighting included on overhead cabinets in loveseat/dinette slideout area, *Progressive Dynamics* 9100 series converter with Charge Wizard.

Titanium

GLENDALERV

31E36MK Fifth Wheel

by Glendale RV
web site: glendalerv.com

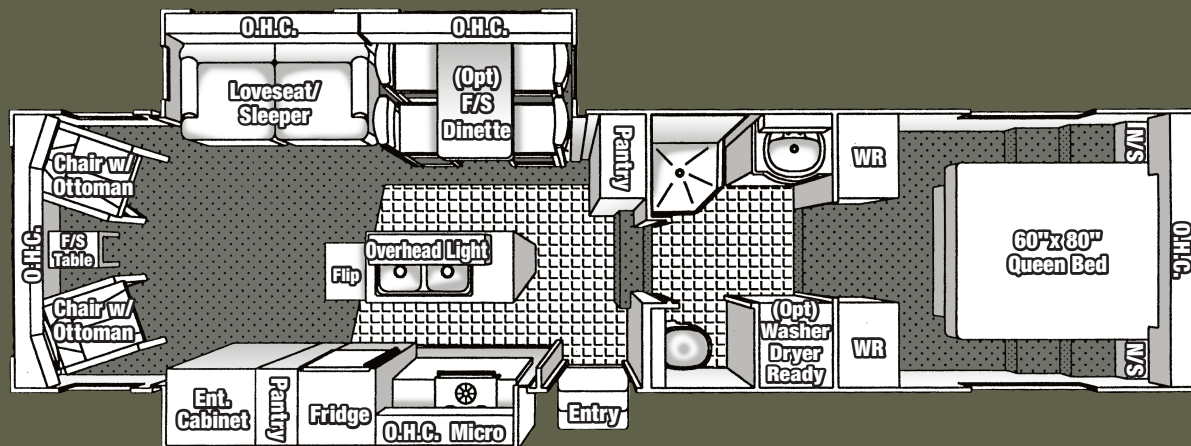

Overall Length	Length - Pin to Bumper	G.V.W.R.	Dry Pin Weight	Dry Weight	Overall Height	Main Body Width
36' - 4"	31' - 2"	11,710 lbs.	1,449 lbs.	9,304 lbs.	12' - 8"	96"

CONSTRUCTION

SIDEWALLS: Vacuum bonded ultra smooth *Lamilux* fiberglass siding. 1-1/2" lightweight aluminum perimeter sidewall framing and 1-1/2" rigid foam insulation.

ROOF: Seamless rubber roof membrane is bonded to 3/8" plywood decking. Full 5-1/2" tapered aluminum truss framing. Thick fiberglass batt insulation. Cathedral ceilings in the bedroom.

FLOOR: Laminated beam floor structure includes 3" foam insulation panel bonded between plywood panels and perimeter framing. *Darco* polythene moisture barrier between chassis underbelly. Seam guard under vinyl floor coverings.

CHASSIS: 11" combination Z channel/steel tube frame construction, twin 6,000 lb. 3" heavy duty axle assemblies, axle shocks at all wheels, *Goodyear* ST235/80R16 "D" radial tires, venting wheel rims, 12" x 2" electric brakes, underslung spare tire and rim, snap release pins on powered front landing gear, powered front landing gear includes a safety shut-off switch, 2 stabilizer jacks, 72 degree adjustable pin box.

SLIDEOUT SPECIFICATIONS: Low maintenance powerful rack and gear 12V direct drive motor system, flush floor design, gear box release lever included for system manual override.

INTERIOR CABINET DOORS: Combination of raised panel and cathedral style mirrored oak cabinet doors. Easy-Glide metal roller system on all drawers.

WINDOWS: Radius corner bronze tinted solar reflective glass.

ENTRANCE DOOR: 30" wide radius corner combination entrance door with screen and dead-bolt lock, easy fold-away 24" triple rise entry steps, fold-away assist handle on entry door, porch light.

APPLIANCES

REFRIGERATOR: *Dometic* 8 cubic ft. double door, 2 way gas/110V.

RANGE: *Wedgewood* High Output 21" 3 burner, piezo ignitor.

FURNACE: *Atwood* 2 stage Excalibur furnace 40,000 BTU ducted in floor heat system.

MICROWAVE OVEN: *Dometic* 24" 1.3 cubic ft. with turntable and built in range hood, light and exhaust fan.

AIR CONDITIONER: *Dometic* Briskair 13,500 BTU thermal insulated ducted in ceiling cool air system.

ENTERTAINMENT

STEREO: DVD/Tuner 5 speaker surround sound (*Mandatory Super Pack*).

BEDROOM STEREO: Stereo 12V CD/Clock radio with remote (*Mandatory Super Pack*).

TV ANTENNA: *Winegard* RV antenna with booster.

TV HOOKUP: Coax cable hookup in bedroom and living area.

TELEPHONE JACK: Standard equipment.

SATELLITE HOOKUP: Pre-wired for quick dish connection to the RV.

AWNING

A&E 20' AWNING: Pewter/White. Awning features patented rugged steel roller tube and heavy duty torsion spring with 8' extension.

PLUMBING & ELECTRICAL

Sealand Traveler Lite foot pedal flush china toilet with hand spray (*mandatory option*), **Lyons** corner shower and surround, single lever brushed nickel faucet in kitchen with sprayer, large brushed nickel double sink (*includes cover*), Euro bath vanity with brushed nickel single lever tap, water heater by-pass kit.

WATER PUMP: *Shur-Flo* Smart Sensor Intelligent Pump (*mandatory option*).

WATER HEATER: *Atwood* fast recovery 10 gallon gas/electric DSI with remote switch operation.

HOLDING TANKS: Holding tanks are enclosed, insulated and heated. Garden style non-freeze drain tap on fresh water tank, sewage tank flush system.

HOLDING TANK CAPACITIES:

FRESH: 48 gallon GREY: 49 gallon SEWAGE: 49 gallon

ELECTRICAL CONVERTER: *Magnetek* 7445 solid state circuitry, whisper quiet operation.

HOOKUP: 50 AMP (*detachable power cord*).

STANDARD FEATURES

Fiberglass front and back end caps, roof rack and ladder, oak edge counter tops, exterior rinse shower, venetian blinds, 2 x 30 lb. propane bottles with auto changeover regulator, systems monitor panel, color coordinated ABS lower sidewall skirting, large under bed storage compartment, 60" x 80" queen bed, smoke detector, french doors in bedroom, chairs with ottomans.

OPTIONAL EQUIPMENT

Twin beds, oak free standing dinette in place of booth style dinette, wall-a-way recliners, day/night shades, thermopane windows, storm windows, aluminum rims, dual exterior security lights, porcelain toilet (*mandatory option*), electric fireplace, washer/dryer ready, skylight in bathroom, dual front power jacks (*mandatory option*), loveseat (*mandatory option*), 27" TV with swivel base, 7,000 lb. axle upgrade.

OPTIONAL FEATURE PACKAGE UPGRADES

INTERIOR PACKAGE: Fluorescent ceiling lights, day/night shades, oak galley area flooring.

COMFORT PACKAGE: 15,000 BTU air conditioner upgrade, *Fantastic* powered roof vent in bedroom, central vacuum, paddle fan.

MANDATORY SUPER PACK FEATURE UPGRADES

Never lube axles, bedroom 12V CD/Clock radio with remote, DVD/Tuner 5 speaker surround sound, bi-fold burner cover, solar panel trickle charger on air conditioner, down draft cool air diverter, brushed nickel single lever kitchen tap set, exterior quick connect for BBQ, new exterior graphics package, mirrored doors in bedroom, cathedral mirrored overhead cabinets in living area, attic vents, oak baseboard and ceiling moldings, overhead cabinet in bedroom, stainless steel look microwave, bullet style lighting included on rear overhead cabinets in living area and loveseat/dinette slideout area.

Titanium

GLENDALERV

32E37 Fifth Wheel

by Glendale RV
web site: glendalerv.com

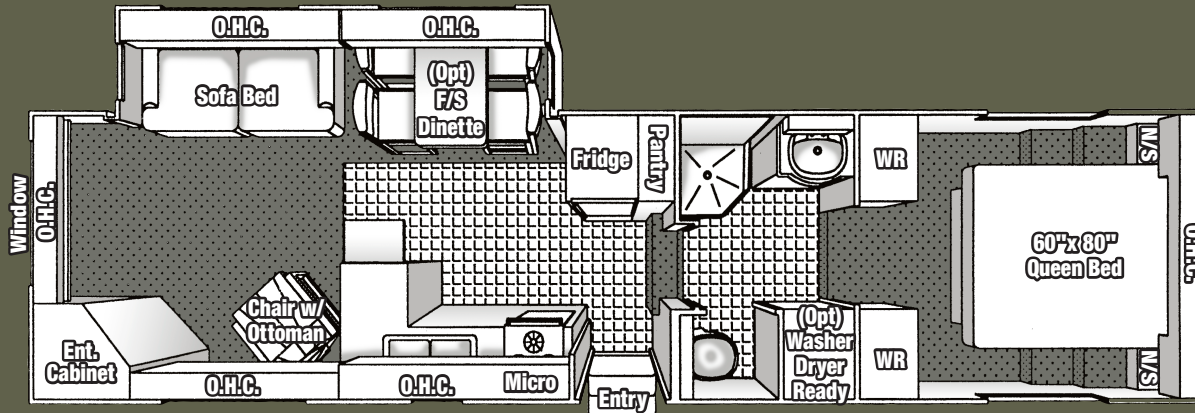

Overall Length	Length - Pin to Bumper	G.V.W.R.	Dry Pin Weight	Dry Weight	Overall Height	Main Body Width
37' - 4"	32' - 2"	11,271 lbs.	1,936 lbs.	8,877 lbs.	12' - 8"	96"

CONSTRUCTION

SIDEWALLS: Vacuum bonded ultra smooth *Lamilux* fiberglass siding. 1-1/2" lightweight aluminum perimeter sidewall framing and 1-1/2" rigid foam insulation.

ROOF: Seamless rubber roof membrane is bonded to 3/8" plywood decking. Full 5-1/2" tapered aluminum truss framing. Thick fiberglass batt insulation. Cathedral ceilings in the bedroom.

FLOOR: Laminated beam floor structure includes 3" foam insulation panel bonded between plywood panels and perimeter framing. *Darco* polyethylene moisture barrier between chassis underbelly. Seam guard under vinyl floor coverings.

CHASSIS: 11" combination Z channel/steel tube frame construction, twin 6,000 lb. 3" heavy duty axle assemblies, axle shocks at all wheels, *Goodyear* ST235/80R16 "D" radial tires, venting wheel rims, 12" x 2" electric brakes, underslung spare tire and rim, snap release pins on powered front landing gear, powered front landing gear includes a safety shut-off switch, 2 stabilizer jacks, 72 degree adjustable pin box.

SLIDEOUT SPECIFICATIONS: Low maintenance powerful rack and gear 12V direct drive motor system, flush floor design, gear box release lever included for system manual override.

INTERIOR CABINET DOORS: Combination of raised panel and cathedral style mirrored oak cabinet doors. Easy-Glide metal roller system on all drawers.

WINDOWS: Radius corner bronze tinted solar reflective glass.

ENTRANCE DOOR: 30" wide radius corner combination entrance door with screen and dead-bolt lock, easy fold-away 24" triple rise entry steps, fold-away assist handle on entry door, porch light.

APPLIANCES

REFRIGERATOR: *Dometic* 8 cubic ft. double door, 2 way gas/110V.

RANGE: *Wedgewood* High Output 21" 3 burner, piezo ignitor.

FURNACE: *Atwood* 2 stage Excalibur furnace 40,000 BTU ducted in floor heat system.

MICROWAVE OVEN: *Dometic* 24" 1.3 cubic ft. with turntable and built in range hood, light and exhaust fan.

AIR CONDITIONER: *Dometic* Briskair 13,500 BTU thermal insulated ducted in ceiling cool air system.

ENTERTAINMENT

STEREO: DVD/Tuner 5 speaker surround sound (*Mandatory Super Pack*).

BEDROOM STEREO: Stereo 12V CD/Clock radio with remote (*Mandatory Super Pack*).

TV ANTENNA: *Winegard* RV antenna with booster.

TV HOOKUP: Coax cable hookup in bedroom and living area.

TELEPHONE JACK: Standard equipment.

SATELLITE HOOKUP: Pre-wired for quick dish connection to the RV.

AWNING

A&E 21' AWNING: Pewter/White. Awning features patented rugged steel roller tube and heavy duty torsion spring with 8' extension.

PLUMBING & ELECTRICAL

Sealand Traveler Lite foot pedal flush china toilet with hand spray (*mandatory option*), **Lyons** corner shower and surround, single lever brushed nickel faucet in kitchen with sprayer, large brushed nickel double sink (*includes cover*), Euro bath vanity with brushed nickel single lever tap, water heater by-pass kit.

WATER PUMP: *Shur-Flo* Smart Sensor Intelligent Pump (*mandatory option*).

WATER HEATER: *Atwood* fast recovery 10 gallon gas/electric DSI with remote switch operation.

HOLDING TANKS: Holding tanks are enclosed, insulated and heated. Garden style non-freeze drain tap on fresh water tank, sewage tank flush system.

HOLDING TANK CAPACITIES:

FRESH: 48 gallon GREY: 49 gallon SEWAGE: 49 gallon

ELECTRICAL CONVERTER: *Magnetek* 7445 solid state circuitry, whisper quiet operation.

HOOKUP: 50 AMP (*detachable power cord*).

STANDARD FEATURES

Fiberglass front and back end caps, roof rack and ladder, oak edge counter tops, exterior rinse shower, venetian blinds, 2 x 30 lb. propane bottles with auto changeover regulator, systems monitor panel, color coordinated ABS lower sidewall skirting, large under bed storage compartment, 60" x 80" queen bed, smoke detector, french doors in bedroom, chairs with ottomans, sofa bed.

OPTIONAL EQUIPMENT

Twin beds, oak free standing dinette in place of booth style dinette, wall-a-way recliners, day/night shades, thermopane windows, storm windows, aluminum rims, dual exterior security lights, porcelain toilet (*mandatory option*), electric fireplace, washer/dryer ready, skylight in bathroom, dual front power jacks (*mandatory option*), 27" stereo TV, 7,000 lb. axle upgrade.

OPTIONAL FEATURE PACKAGE UPGRADES

INTERIOR PACKAGE: Fluorescent ceiling lights, day/night shades, oak galley area flooring.

COMFORT PACKAGE: 15,000 BTU air conditioner upgrade, *Fantastic* powered roof vent in bedroom, central vacuum, paddle fan.

MANDATORY SUPER PACK FEATURE UPGRADES

Never lube axles, bedroom 12V CD/Clock radio with remote, DVD/Tuner 5 speaker surround sound, bi-fold burner cover, solar panel trickle charger on air conditioner, down draft cool air diverter, brushed nickel single lever kitchen tap set, exterior quick connect for BBQ, new exterior graphics package, mirrored doors in bedroom, cathedral mirrored overhead cabinets in living area, attic vents, oak baseboard and ceiling moldings, overhead cabinet in bedroom, stainless steel look microwave, bullet style lighting included on rear overhead cabinets in living area and sofa slideout area.

Titanium

GLENDALERV

32E37DS

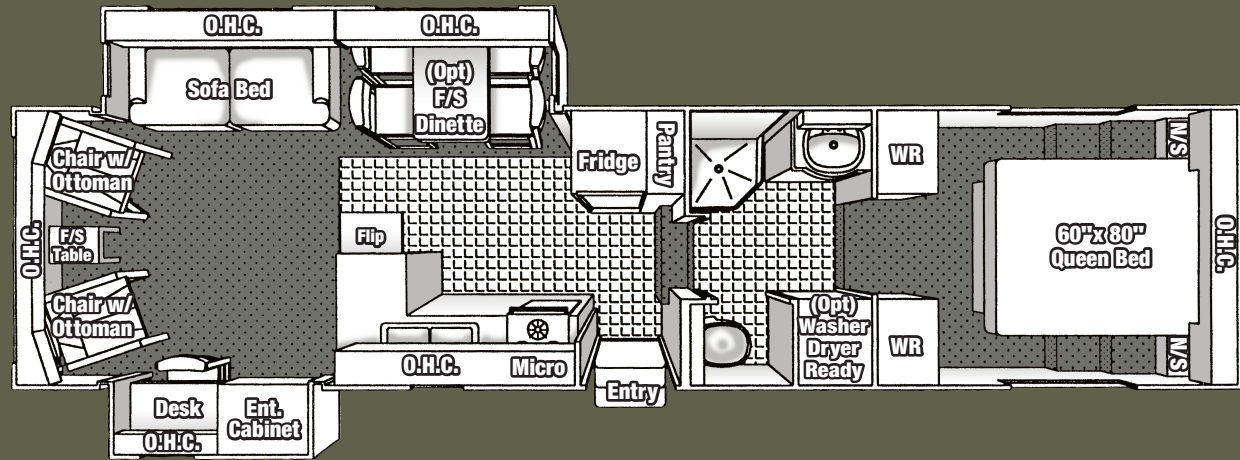

Overall Length	Length - Pin to Bumper	G.V.W.R.	Dry Pin Weight	Dry Weight	Overall Height	Main Body Width
37' - 4"	32' - 2"	11,658 lbs.	1,817 lbs.	9,249 lbs.	12' - 8"	96"

CONSTRUCTION

SIDEWALLS: Vacuum bonded ultra smooth *Lamilux* fiberglass siding. 1-1/2" lightweight aluminum perimeter sidewall framing and 1-1/2" rigid foam insulation.

ROOF: Seamless rubber roof membrane is bonded to 3/8" plywood decking. Full 5-1/2" tapered aluminum truss framing. Thick fiberglass batt insulation. Cathedral ceilings in the bedroom.

FLOOR: Laminated beam floor structure includes 3" foam insulation panel bonded between plywood panels and perimeter framing. *Darco* polythene moisture barrier between chassis underbelly. Seam guard under vinyl floor coverings.

CHASSIS: 11" combination Z channel/steel tube frame construction, twin 6,000 lb. 3" heavy duty axle assemblies, axle shocks at all wheels, *Goodyear* ST235/80R16 "D" radial tires, venting wheel rims, 12" x 2" electric brakes, underslung spare tire and rim, snap release pins on powered front landing gear, powered front landing gear includes a safety shut-off switch, 2 stabilizer jacks, 72 degree adjustable pin box.

SLIDEOUT SPECIFICATIONS: Low maintenance powerful rack and gear 12V direct drive motor system, flush floor design, gear box release lever included for system manual override.

INTERIOR CABINET DOORS: Combination of raised panel and cathedral style mirrored oak cabinet doors. Easy-Glide metal roller system on all drawers.

WINDOWS: Radius corner bronze tinted solar reflective glass.

ENTRANCE DOOR: 30" wide radius corner combination entrance door with screen and dead-bolt lock, easy fold-away 24" triple rise entry steps, fold-away assist handle on entry door, porch light.

APPLIANCES

REFRIGERATOR: *Dometic* 8 cubic ft. double door, 2 way gas/110V.

RANGE: *Wedgewood* High Output 21" 3 burner, piezo ignitor.

FURNACE: *Atwood* 2 stage Excalibur furnace 40,000 BTU ducted in floor heat system.

MICROWAVE OVEN: *Dometic* 24" 1.3 cubic ft. with turntable and built in range hood, light and exhaust fan.

AIR CONDITIONER: *Dometic* Briskair 13,500 BTU thermal insulated ducted in ceiling cool air system.

ENTERTAINMENT

STEREO: DVD/Tuner 5 speaker surround sound (*Mandatory Super Pack*).

BEDROOM STEREO: Stereo 12V CD/Clock radio with remote (*Mandatory Super Pack*).

TV ANTENNA: *Winegard* RV antenna with booster.

TV HOOKUP: Coax cable hookup in bedroom and living area.

TELEPHONE JACK: Standard equipment.

SATELLITE HOOKUP: Pre-wired for quick dish connection to the RV.

AWNING

A&E 15' AWNING: Pewter/White. Awning features patented rugged steel roller tube and heavy duty torsion spring with 8' extension.

PLUMBING & ELECTRICAL

Sealand Traveler Lite foot pedal flush china toilet with hand spray (*mandatory option*), **Lyons** corner shower and surround, single lever brushed nickel faucet in kitchen with sprayer, large brushed nickel double sink (*includes cover*), large white bath vanity with brushed nickel single lever tap, water heater by-pass kit.

WATER PUMP: *Shur-Flo* Smart Sensor Intelligent Pump (*mandatory option*).

WATER HEATER: *Atwood* fast recovery 10 gallon gas/electric DSI with remote switch operation.

HOLDING TANKS: Holding tanks are enclosed, insulated and heated. Garden style non-freeze drain tap on fresh water tank, sewage tank flush system.

HOLDING TANK CAPACITIES:

FRESH: 48 gallon GREY: 49 gallon SEWAGE: 49 gallon

ELECTRICAL CONVERTER: *Magnetek* 7445 solid state circuitry, whisper quiet operation.

HOOKUP: 50 AMP (*detachable power cord*).

STANDARD FEATURES

Fiberglass front and back end caps, roof rack and ladder, oak edge counter tops, exterior rinse shower, venetian blinds, 2 x 30 lb. propane bottles with auto changeover regulator, systems monitor panel, color coordinated ABS lower sidewall skirting, large under bed storage compartment, 60" x 80" queen bed, smoke detector, french doors in bedroom, chairs with ottomans, sofa bed.

OPTIONAL EQUIPMENT

Twin beds, oak free standing dinette in place of booth style dinette, wall-a-way recliners, day/night shades, thermopane windows, storm windows, aluminum rims, dual exterior security lights, porcelain toilet (*mandatory option*), electric fireplace, washer/dryer ready, skylight in bathroom, dual front power jacks (*mandatory option*), 27" TV with swivel base, 7,000 lb. axle upgrade, rear patio deck.

OPTIONAL FEATURE PACKAGE UPGRADES

INTERIOR PACKAGE: Fluorescent ceiling lights, day/night shades, oak galley area flooring.

COMFORT PACKAGE: 15,000 BTU air conditioner upgrade, *Fantastic* powered roof vent in bedroom, central vacuum, paddle fan.

MANDATORY SUPER PACK FEATURE UPGRADES

Never lube axles, bedroom 12V CD/Clock radio with remote, DVD/Tuner 5 speaker surround sound, bi-fold burner cover, solar panel trickle charger on air conditioner, down draft cool air diverter, brushed nickel single lever kitchen tap set, exterior quick connect for BBQ, new exterior graphics package, mirrored doors in bedroom, cathedral mirrored overhead cabinets in living area, attic vents, oak baseboard and ceiling mouldings, overhead cabinet in bedroom, stainless steel look microwave, bullet style lighting included on rear overhead cabinets in living area and sofa slideout area.

Titanium

GLENDALERV

33E38TS

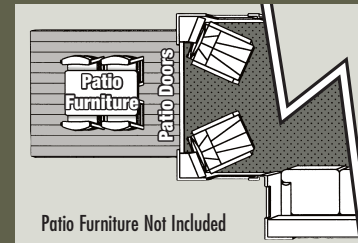
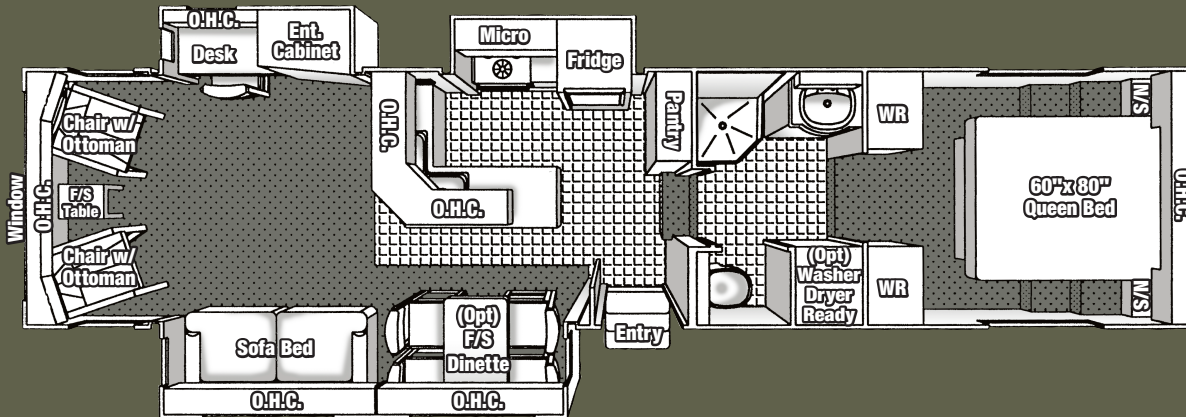

OPTIONAL FLOORPLAN
Rear Deck Patio
Screen Room

Patio Furniture Not Included

Patent Pending

Overall Length	Length - Pin to Bumper	G.V.W.R.	Dry Pin Weight	Dry Weight	Overall Height	Main Body Width
39' - 1"	33' - 11"	12,875 lbs.	2,205 lbs.	10,273 lbs.	12' - 8"	96"

CONSTRUCTION

SIDEWALLS: Vacuum bonded ultra smooth *Lamilux* fiberglass siding. 1-1/2" lightweight aluminum perimeter sidewall framing and 1-1/2" rigid foam insulation.

ROOF: Seamless rubber roof membrane is bonded to 3/8" plywood decking. Full 5-1/2" tapered aluminum truss framing. Thick fiberglass batt insulation. Cathedral ceilings in the bedroom.

FLOOR: Laminated beam floor structure includes 3" foam insulation panel bonded between plywood panels and perimeter framing. *Darco* polyethylene moisture barrier between chassis underbelly. Seam guard under vinyl floor coverings.

CHASSIS: 11" combination Z channel/steel tube frame construction, twin 6,000 lb. 3" heavy duty axle assemblies, axle shocks at all wheels, *Goodyear* ST235/80R16 "D" radial tires, venting wheel rims, 12" x 2" electric brakes, underslung spare tire and rim, snap release pins on powered front landing gear, powered front landing gear includes a safety shut-off switch, 2 stabilizer jacks, 72 degree adjustable pin box.

SLIDEOUT SPECIFICATIONS: Low maintenance powerful rack and gear 12V direct drive motor system, flush floor design, gear box release lever included for system manual override.

INTERIOR CABINET DOORS: Combination of raised panel and cathedral style mirrored oak cabinet doors. Easy-Glide metal roller system on all drawers.

WINDOWS: Radius corner bronze tinted solar reflective glass.

ENTRANCE DOOR: 30" wide radius corner combination entrance door with screen and dead-bolt lock, easy fold-away 24" triple rise entry steps, fold-away assist handle on entry door, porch light.

APPLIANCES

REFRIGERATOR: *Dometic* 8 cubic ft. double door, 2 way gas/110V.

RANGE: *Wedgewood* High Output 21" 3 burner, piezo ignitor.

FURNACE: *Atwood* 2 stage Excalibur furnace 40,000 BTU ducted in floor heat system.

MICROWAVE OVEN: *Dometic* 24" 1.3 cubic ft. with turntable and built in range hood, light and exhaust fan.

AIR CONDITIONER: *Dometic* Briskair 13,500 BTU thermal insulated ducted in ceiling cool air system.

ENTERTAINMENT

STEREO: DVD/Tuner 5 speaker surround sound (*Mandatory Super Pack*).

BEDROOM STEREO: Stereo 12V CD/Clock radio with remote (*Mandatory Super Pack*).

TV ANTENNA: *Winegard* RV antenna with booster.

TV HOOKUP: Coax cable hookup in bedroom and living area.

TELEPHONE JACK: Standard equipment.

SATELLITE HOOKUP: Pre-wired for quick dish connection to the RV.

AWNING

A&E 12' AWNING: Pewter/White. Awning features patented rugged steel roller tube and heavy duty torsion spring with 8' extension.

PLUMBING & ELECTRICAL

Sealand Traveler Lite foot pedal flush china toilet with hand spray (*mandatory option*), **Lyons** corner shower and surround, single lever brushed nickel faucet in kitchen with sprayer, large corner brushed nickel double sink (*includes cover*), Euro bath vanity with brushed nickel single lever tap, water heater by-pass kit.

WATER PUMP: *Shur-Flo* Smart Sensor Intelligent Pump (*mandatory option*).

WATER HEATER: *Atwood* fast recovery 10 gallon gas/electric DSI with remote switch operation.

HOLDING TANKS: Holding tanks are enclosed, insulated and heated. Garden style non-freeze drain tap on fresh water tank, sewage tank flush system.

HOLDING TANK CAPACITIES:

FRESH: 63 gallon GREY: 49 gallon SEWAGE: 49 gallon

ELECTRICAL CONVERTER: *Magnetek* 7445 solid state circuitry, whisper quiet operation.

HOOKUP: 50 AMP (*detachable power cord*).

STANDARD FEATURES

Fiberglass front and back end caps, roof rack and ladder, oak edge counter tops, exterior rinse shower, venetian blinds, 2 x 30 lb. propane bottles with auto changeover regulator, systems monitor panel, color coordinated ABS lower sidewall skirting, large under bed storage compartment, 60" x 80" queen bed, smoke detector, french doors in bedroom, chairs with ottomans, sofa bed.

OPTIONAL EQUIPMENT

Twin beds, oak free standing dinette in place of booth style dinette, wall-a-way recliners, day/night shades, thermopane windows, storm windows, aluminum rims, dual exterior security lights, porcelain toilet (*mandatory option*), electric fireplace, washer/dryer ready, skylight in bathroom, dual front power jacks (*mandatory option*), 27" stereo TV, 7,000 lb. axle upgrade.

OPTIONAL FEATURE PACKAGE UPGRADES

INTERIOR PACKAGE: Fluorescent ceiling lights, day/night shades, oak galley area flooring.

COMFORT PACKAGE: 15,000 BTU air conditioner upgrade, *Fantastic* powered roof vent in bedroom, central vacuum, paddle fan.

MANDATORY SUPER PACK FEATURE UPGRADES

Never lube axles, bedroom 12V CD/Clock radio with remote, DVD/Tuner 5 speaker surround sound, bi-fold burner cover, solar panel trickle charger on air conditioner, down draft cool air diverter, brushed nickel single lever kitchen tap set, exterior quick connect for BBQ, new exterior graphics package, mirrored doors in bedroom, cathedral mirrored overhead cabinets in living area, attic vents, oak baseboard and ceiling mouldings, overhead cabinet in bedroom, stainless steel look microwave, bullet style lighting included on rear overhead cabinets in living area and sofa/dinette slideout area.

STREAMLINED

**SIGNIFICANT
FUEL SAVINGS**

**EXCEPTIONAL
ROAD HANDLING**

This illustration demonstrates how air flow is swept away from the pin box area of the fifth wheel.

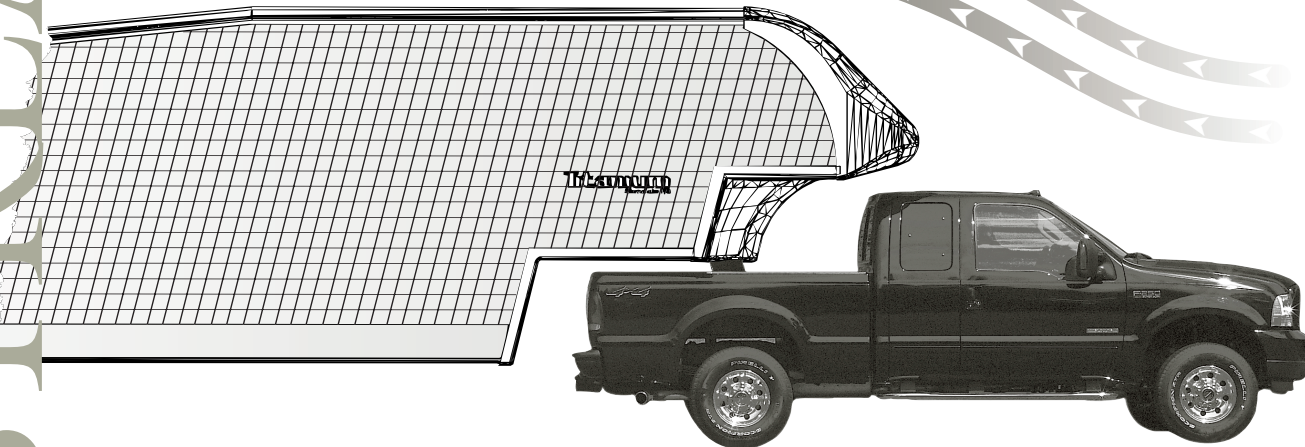
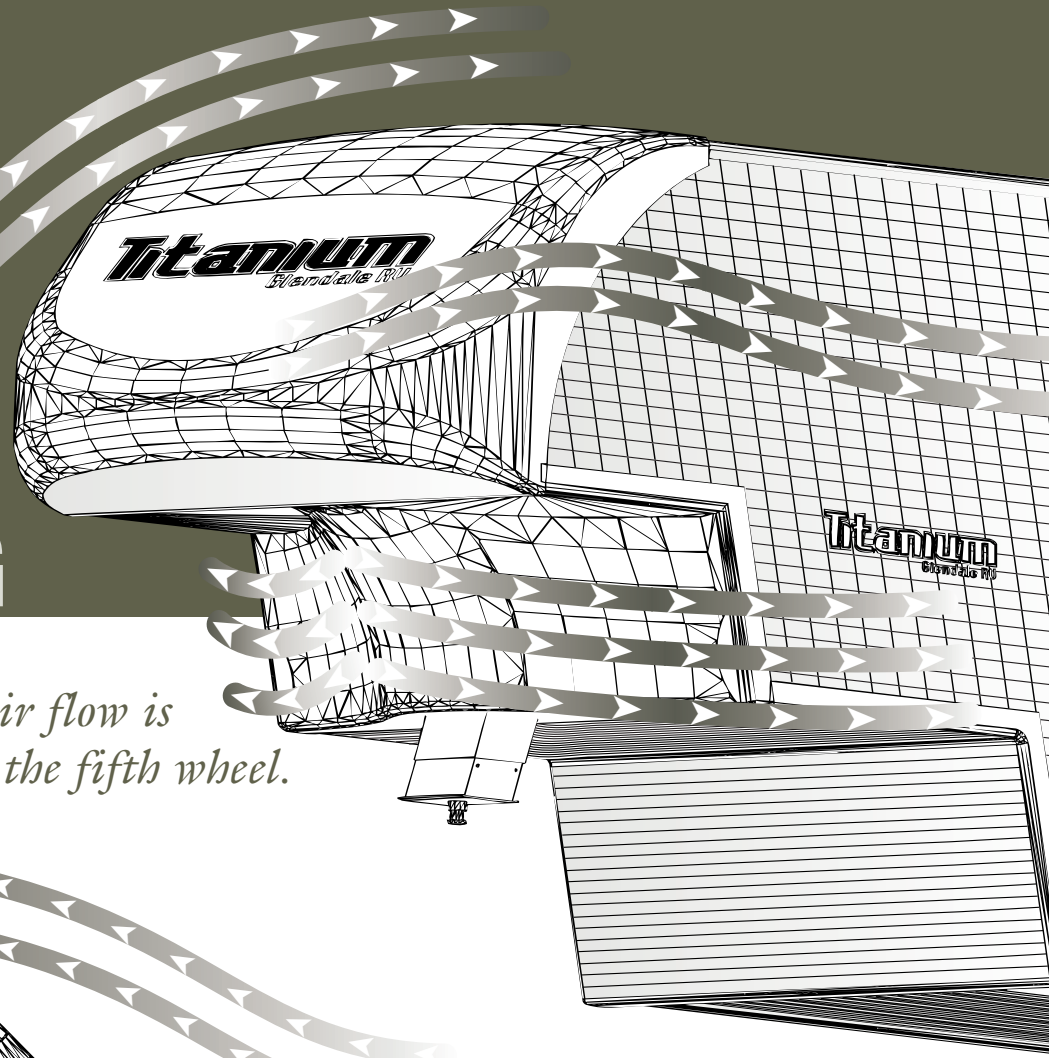

Titanium's patented front cap design provides a natural air foil that appears to mold itself over the cab area of the pick-up contributing to:

- **SIGNIFICANT FUEL SAVING**
- **EXCEPTIONAL ROAD HANDLING**
- **REDUCED WIND DRAG**

REDUCED WIND DRAG

A word about this Guide

The units described in this guide incorporate components produced by Glendale Recreational Vehicles and related companies and suppliers. During manufacturing, different components than initially scheduled may be used. All illustrations and specifications contained in this book are based on the latest product information available at the time of publication approval. However, because we continually upgrade and improve our product, the right is reserved to make changes at any time, without notice, in colours, materials, equipment, specifications and models. We also reserve the right to add or discontinue models without prior notice. Some equipment shown or described throughout this guide may only be available at extra cost and/or may only be available prior to production. Some options may not be available when your unit is built. Photos and drawings are representative of the products and may differ from actual production models. HOLDING TANK CAPACITIES = U.S. Gallons.

Titanium®

"US PATENT 6,394,533"

Fifth Wheel Specifications

Model	24E29	26E31DS	28E33	28E33B	28E33SB	29E34	29E34MS	29E34RL	30E35DS	30E35RB	31E36MK	32E37	32E37DS	33E38TS
Sleeps	4	4	6	8	6	6	6	4	6	9	6	6	6	6
Overall Length	29'-3"	31'-11"	33'-4"	33'-10"	33'-3"	35'-1"	35'-1"	34'-11"	36'-4"	35'-10"	36'-4"	37'-4"	37'-4"	39'-1"
Overall Exterior Height	12'-5"	12'-6"	12'-7"	12'-4"	12'-7"	12'-8"	12'-8"	12'-8"	12'-8"	12'-8"	12'-8"	12'-8"	12'-8"	12'-8"
Dry Pin Weight (lbs)	1,521	1,709	1,460	1,679	1,489	1,478	1,443	1,727	1,591	1,657	1,449	1,936	1,817	2,205
Dry Weight (lbs)	6,856	8,392	8,113	7,996	8,171	8,422	8,351	8,545	9,460	8,708	9,304	8,877	9,249	10,273
G.V.W.R.(lbs)	8,772	10,614	10,436	10,140	10,350	10,725	10,571	10,802	11,915	10,994	11,710	11,271	11,658	12,875
Main Body Width	8'	8'	8'	8'	8'	8'	8'	8'	8'	8'	8'	8'	8'	8'
Interior Height Measurement (Floor to Ceiling)														
Max. Living Area Height	81"	81"	81"	81"	81"	90"	90"	90"	90"	90"	90"	90"	90"	90"
Max. Bedroom Height	77"	77"	77"	77"	77"	77"	77"	77"	77"	77"	77"	77"	77"	77"
Pin Box Area Clearance	60"	60"	60"	60"	60"	60"	60"	60"	60"	60"	60"	60"	60"	60"

Our team of Engineers take full advantage of the testing capabilities offered by the BOSCH Automotive Proving Grounds test facilities in New Carlisle, Indiana. Titanium fifth wheels are put to the road test for both towability and product durability evaluations. The results of these tests help to continually improve our products.



Titanium's "NEW" Optional Scooter Lift. Available on our Model 30E35RB.

Operates at the push of a button and SIMPLY by guiding the lift arm allows for easy access in or out of your RV.

"No unsafe ramps, or manual lifting!"

Contact your dealer for more information.

Titanium[®]

GLENDALE RV



Contact your local dealer for product specifications and available floor plans. *Test Tow this exciting Fifth Wheel Design Today...*

3 YEAR LIMITED STRUCTURE WARRANTY

You can travel with confidence knowing that Glendale provides specific structural warranty coverage for a period of 3 years. All of our warranty commitments are valid in both Canada and the United States. All appliances are name-brand highly regarded products. See dealer for complete warranty details.

Your Local Titanium Dealer:

GLENDALE RV

145 Queen Street, Strathroy, Ontario N7G 3J6

www.glendalerv.com